

HIGHWAY LANDSCAPE DEVELOPMENT PROJECT

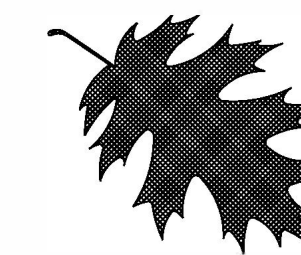

T.I.P. #	STATE PROJECT W.B.S. #	SHEET #	SHEET # TOTAL
R-2303D(L)	34416.3.15	L1	19
FED. PROJ. #	DESCRIPTION		DIVISION
-----	TIP		3

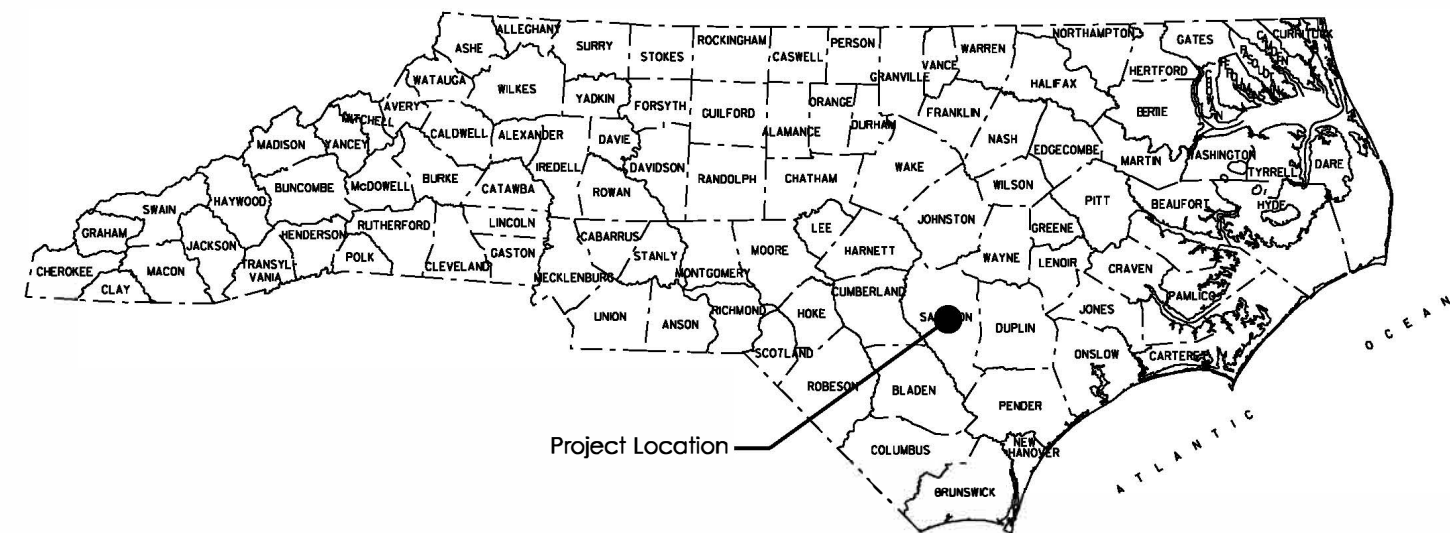

Summary of Quantities
1 Year Establishment

DES	SEC	QTY	UNIT	KEY	BOTANICAL NAME	COMMON NAME	SIZE	CALIPER	FURNISH	A.S.N.S.	NOTES
Grasses/Groundcovers/Perennials											
L	sp	7257	sy	TB	<i>Cynodon dactylon</i> x <i>C. transvaalensis</i> germplasma	Tifway 419 Bermuda	n/a		Sod	n/a	Tight Seams
Other Vegetation Costs											
L	SP	6924	sqft		Brick Pavers (Terra cotta) (Quantity includes 10% extra)						
L	SP	1	LS		Gateway Sign						
L	1670	16	ea		Monthly Maintenance						
L	1101	1	LS		Temporary Traffic Control						
L	1670	82	m/g		Water for Planting						
[] - Alternative Plant Option											
m/g - 1,000 gallons											

NOTES:

- Existing conditions shown on the plans are based on survey information and roadway plans. actual site conditions may vary.
- Prior to any demolition or work taking place, the contractor shall locate and verify all utility lines and structures within the construction areas (water, sewer, gas, electrical, etc.)
- The contractor shall take the necessary precautions to prevent damage of adjacent plant material, facilities, and structures to remain. The contractor shall restore disturbed areas to their original condition and to the satisfaction of the Division Roadside Environmental Engineer.
- The utilities shown on the plans are approximate locations. The contractor shall locate and protect in place all existing utilities before digging occurs and major construction begins.
- Demolition, removal, and disposal of items from the site must be completely in accordance with the law. The contractor is responsible for making a site visit to determine and verify all demolition requirements prior to bidding.
- The contractor shall verify all conditions and dimensions at the job site prior to construction, and if discrepancies are found, notify the Division Roadside Environmental Engineer for clarification.

R-2303D(L) NC-24 CORRIDOR LANDSCAPE IN CLINTON

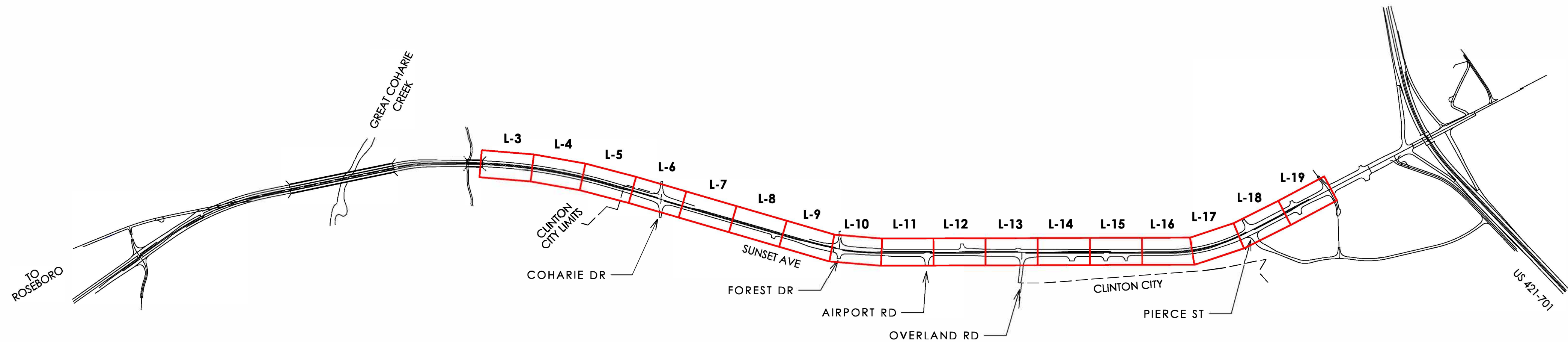
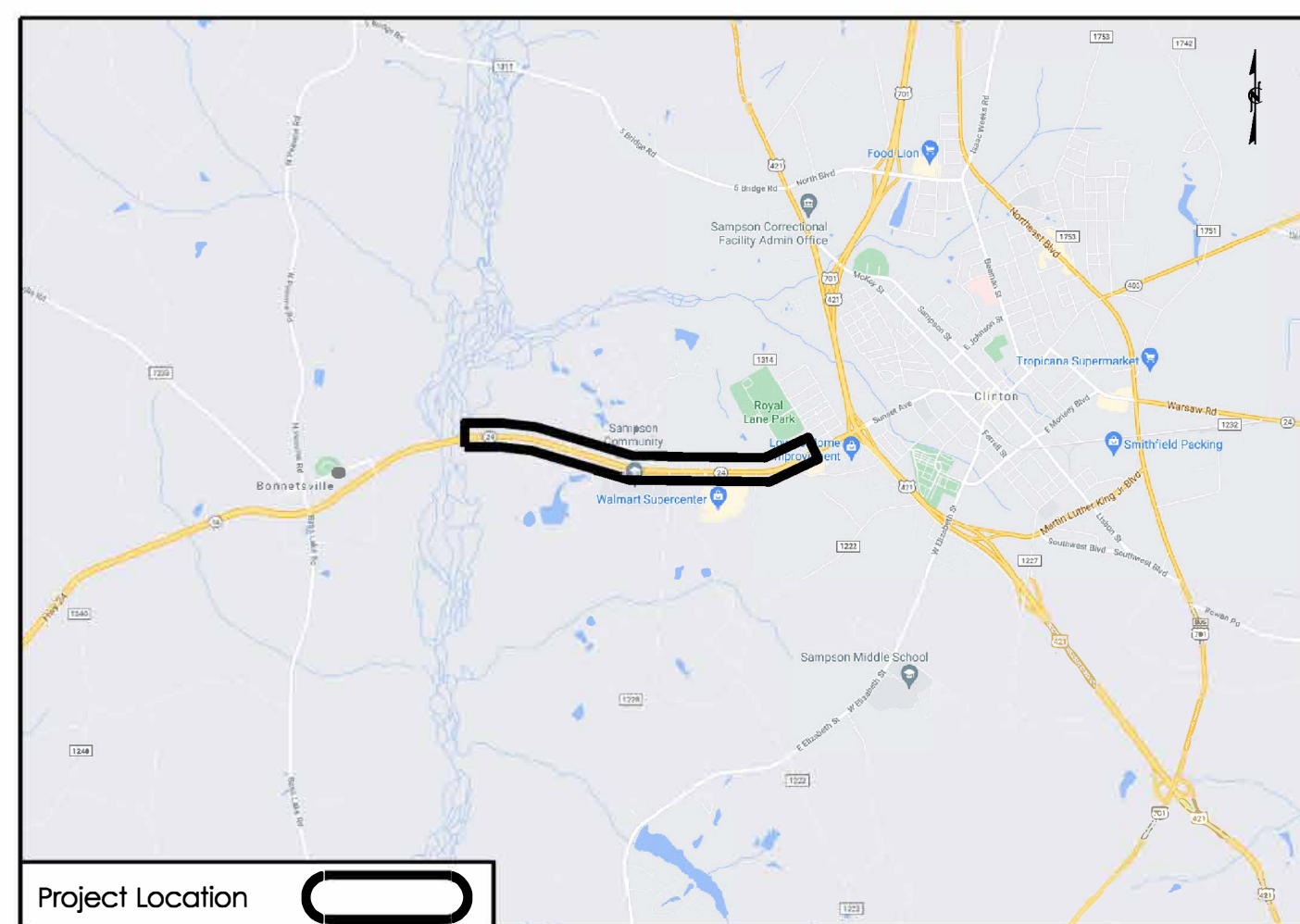

CONVENTIONAL SYMBOLS

Exist. Right of Way Line Marker	---	△
Prop. Right of Way Line Marker (By Others)	---	▲
Prop. Right of Way Line Marker (By Contract)	---	▲
Exist. Control of Access Line	---	○
Prop. Control of Access Line	---	○
Property Line	---	○
Easement Line	---	○
Slope Stake Line	---	+
Exist. Fence	---	+
Prop. Woven Wire Fence	---	○
Prop. Chain Link Fence	---	○
Exist. Road	---	---
Prop. Road	---	---
Guardrail	---	---
Survey Line	---	---
Denotes Line Equality	---	○
Bridge	---	---
Culvert	---	---
Railroad	---	---
Woods	---	---
Exist. Telephone Pole	---	○
Prop. Telephone Pole	---	○
Tower Pole and Line	---	---
Exist. Power Pole	---	○
Prop. Power Pole	---	○
Sanitary Sewer Line	---	---
Water Line	---	---
Gas Line	---	---

INDEX OF L SHEETS:

- L 1.0 - Title Sheet
- L 2.0 - Gateway Sign Details
- L 3.0 - L 19.0 - Planting Plans

PREPARED BY: B Kopetsky DATE: 9/15/21

REVISIONS

DATE	DESCRIPTION

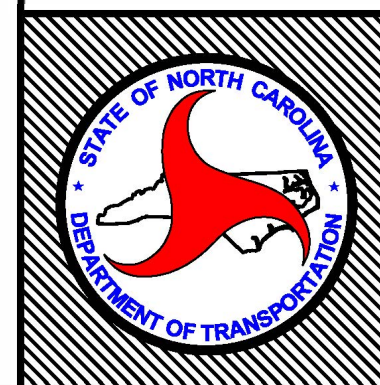

STATE OF
NORTH CAROLINA
DEPARTMENT OF TRANSPORTATION

LOCATION: NC-24 in Clinton

TYPE of WORK: TIP

COUNTY: Sampson

2014 American Standard for Nursery Stock
2018 NCDOT STANDARD SPECIFICATIONS
PREPARED IN THE OFFICE OF:
NCDOT- ROADSIDE ENVIRONMENTAL UNIT
AESTHETIC ENGINEERING SECTION
1557 MAIL SERVICE CENTER
RALEIGH, NC 27699 919-707-2920

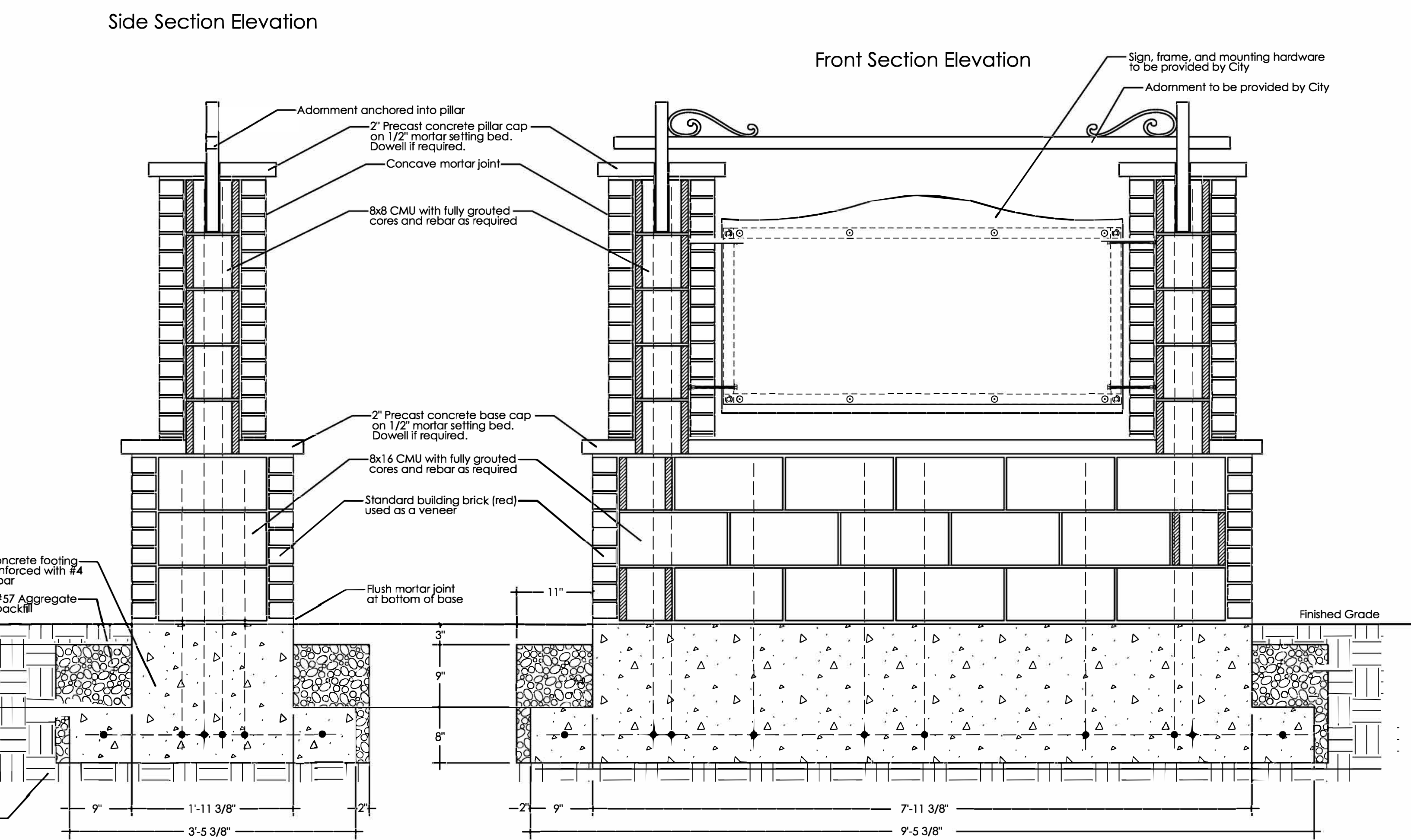
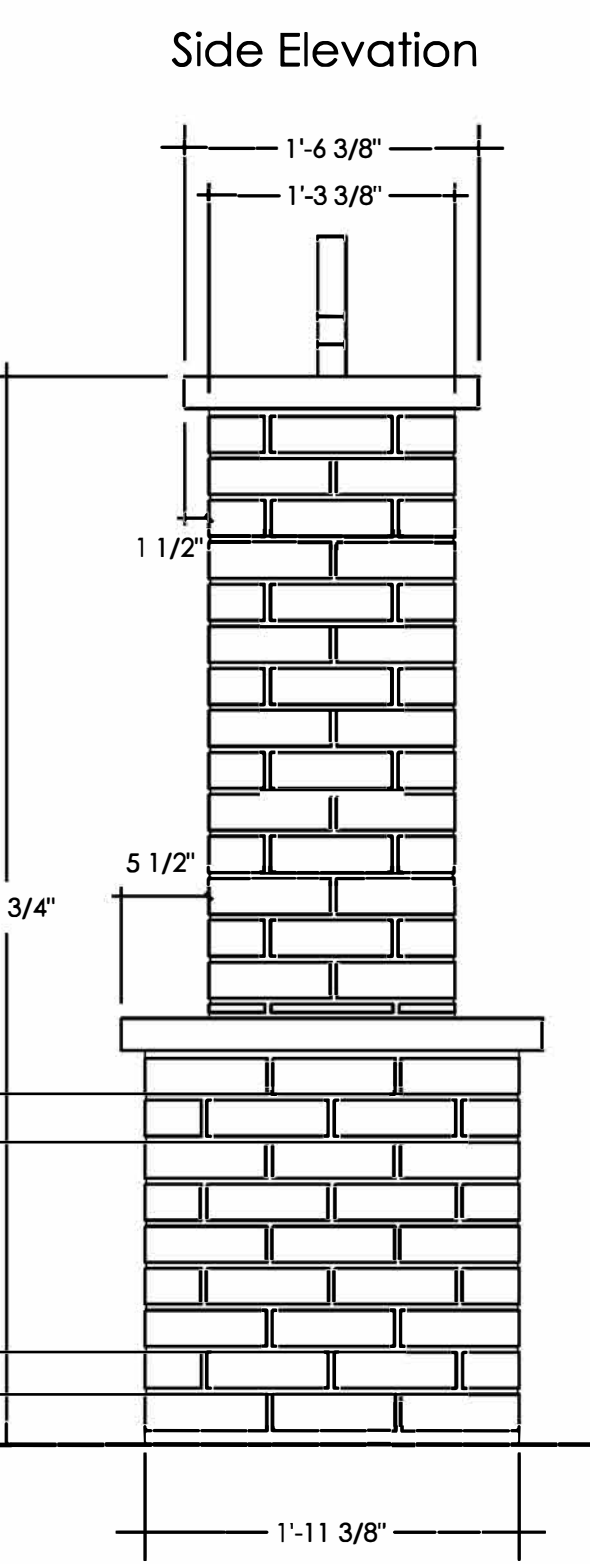
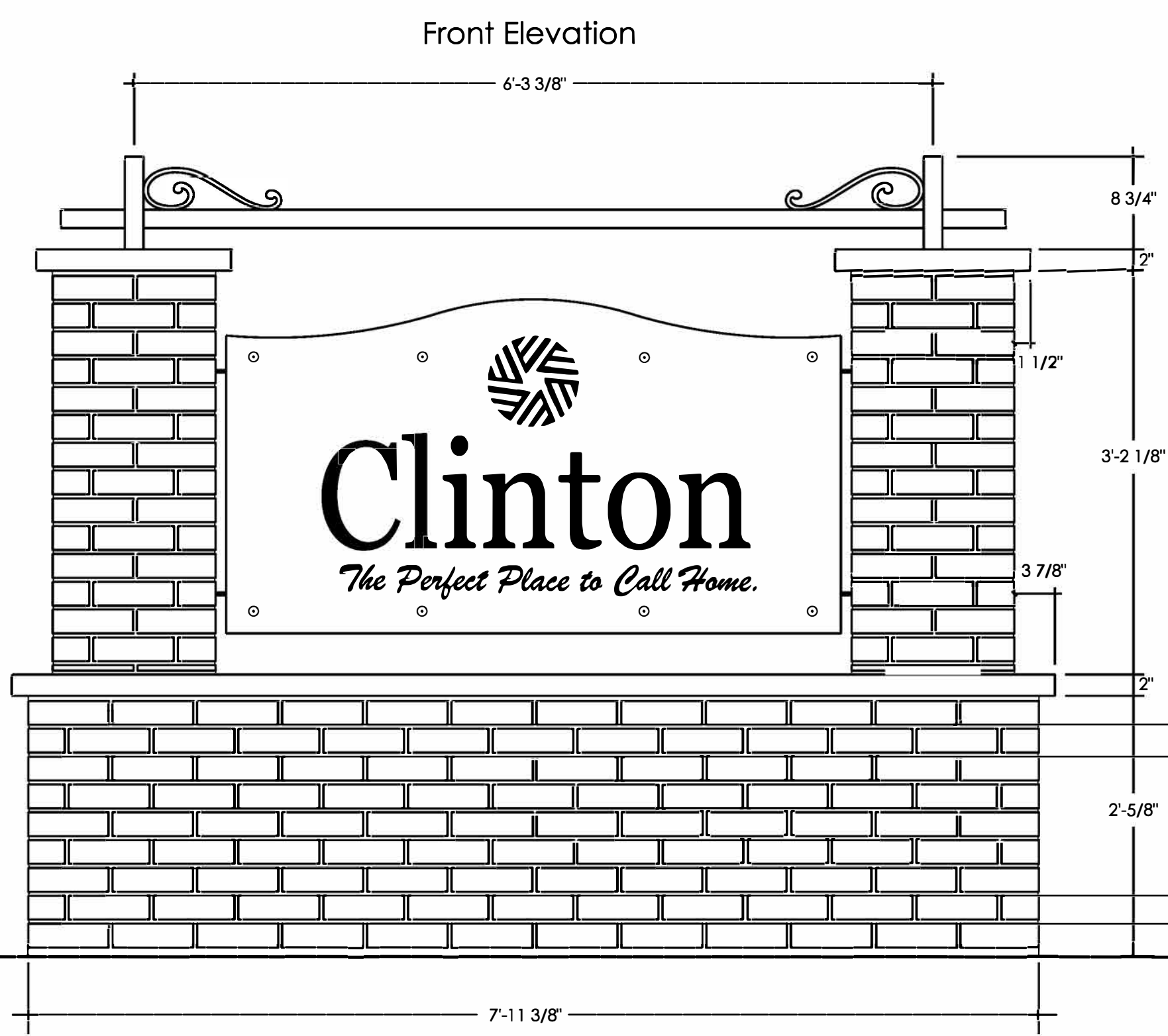
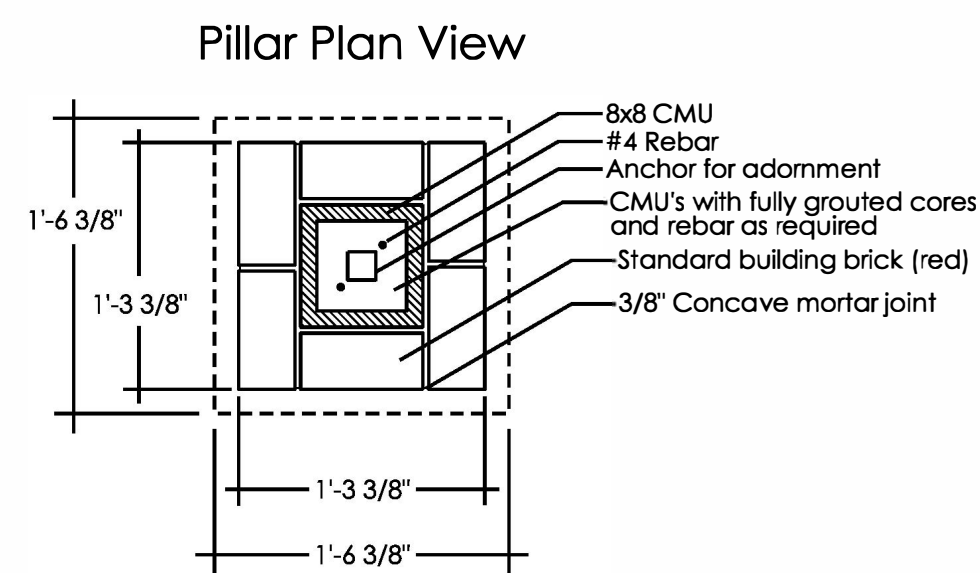
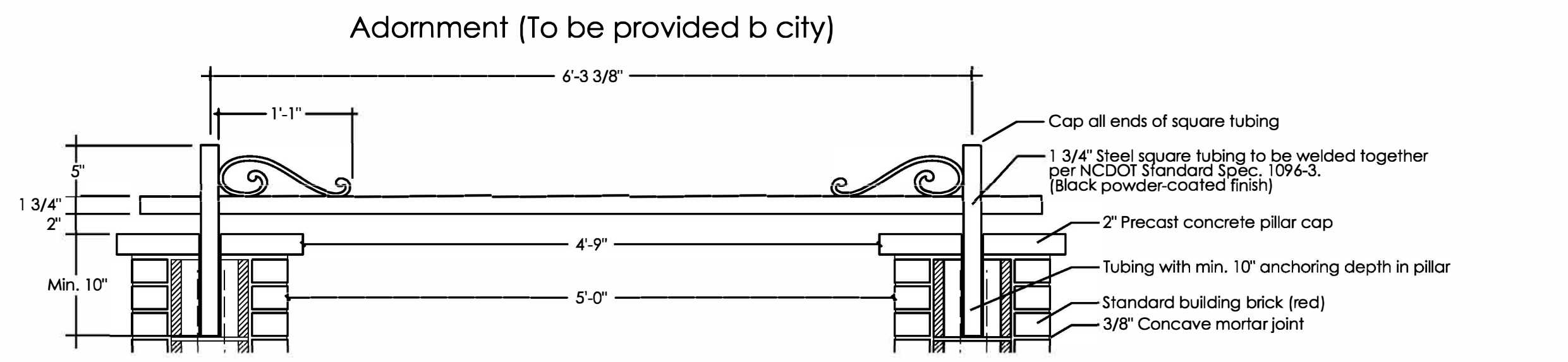
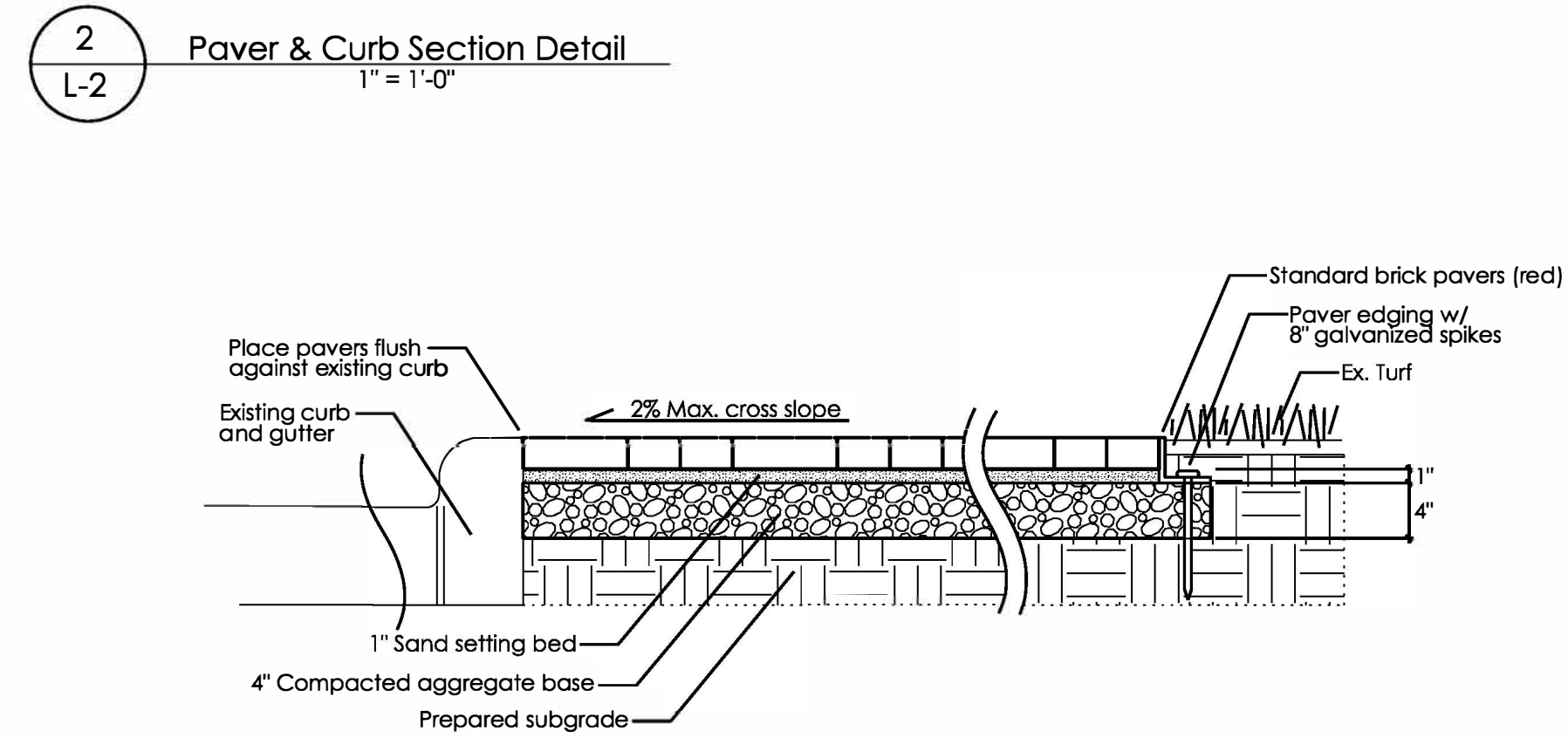
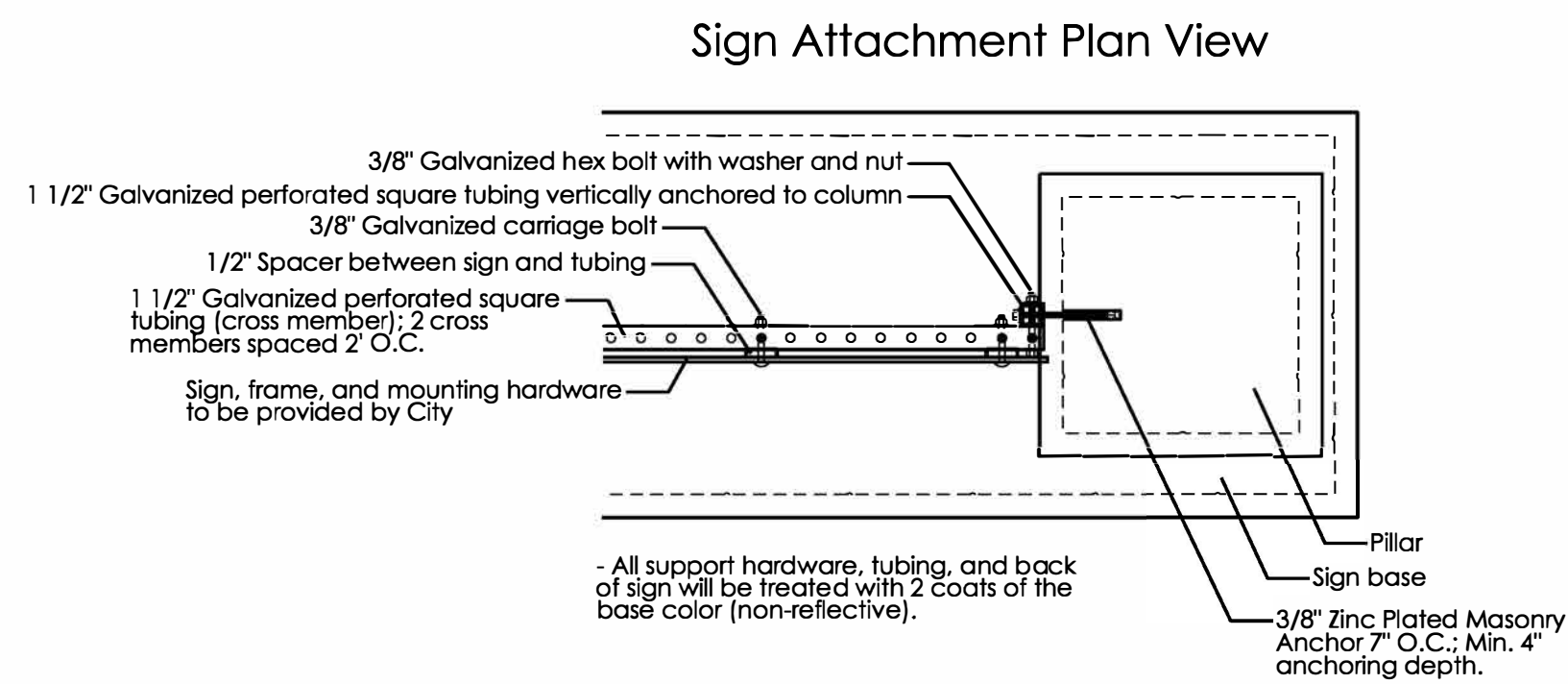
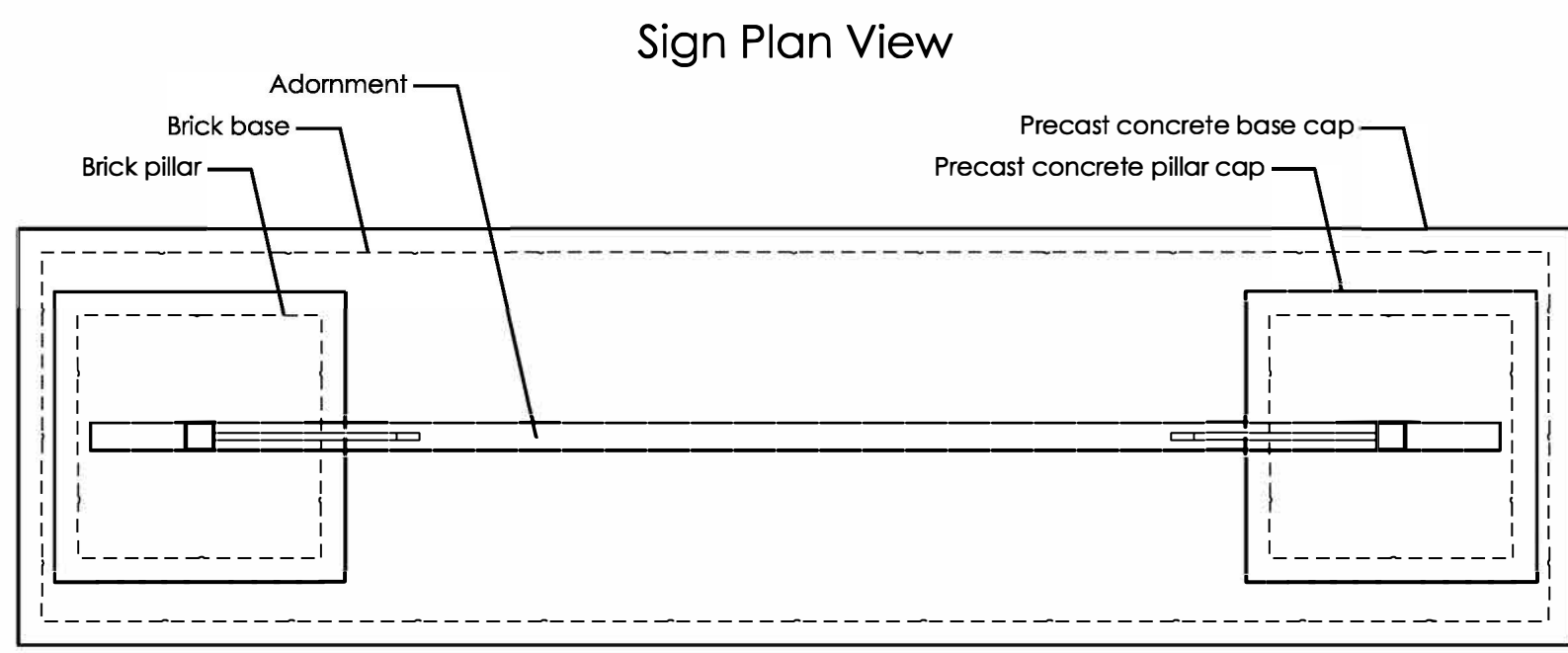

1 Clinton Gateway Sign Details
1" = 1'-0"

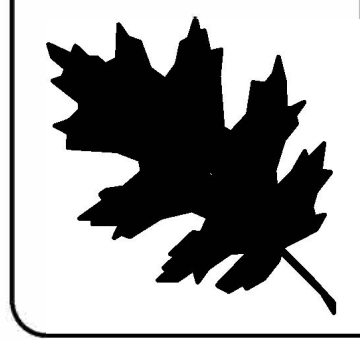

NCDOT - ROADSIDE ENVIRONMENTAL UNIT
AESTHETIC ENGINEERING SECTION
1557 MAIL SERVICE CENTER RALEIGH NC 27699-1557
PH: 919-707-2935 FAX: 919-715-2554
http://www.ncdot.org/doh/operations/dp_chief_eng/roadside/

NC-24 Corridor Landscape in Clinton
Sampson County
TIP #: R-2303D(L)

Landscape Architect
Bob Kopetsky

SHEET DESCRIPTION:
PREL. DESIGN DATE: 7/21/21
CHECKED BY & DATE: K Cooper
FINAL DESIGN DATE: 8/17/21

Gateway Sign Details
Landscape Plan Sheet

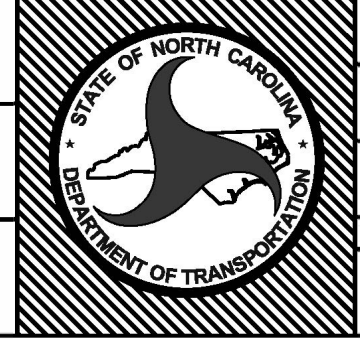

T.I.P. # R-2303D(L)
WBS # 34416.3.15
FED I.D. # -
SHEET NO.: L-2
TOTAL SHEET NO.: L-19

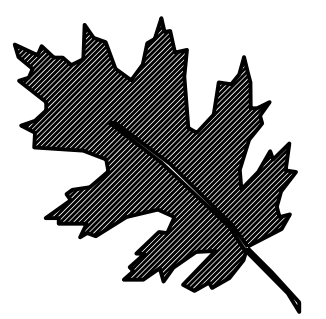
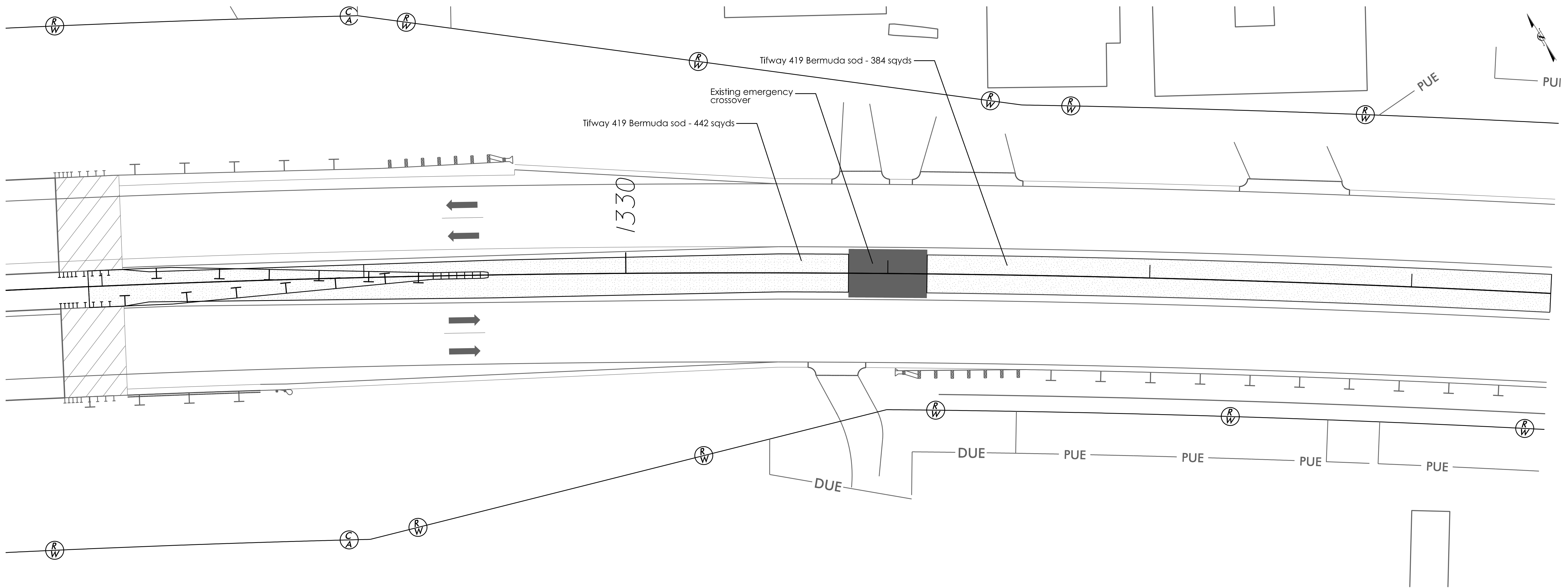

NCDOT - ROADSIDE ENVIRONMENTAL UNIT
 AESTHETIC ENGINEERING SECTION
 1557 MAIL SERVICE CENTER RALEIGH NC 27699-1557
 PH: 919-707-2935 FAX: 919-715-2554
http://www.ncdot.org/doh/operations/dp_chief_eng/roadside/

NC-24 Corridor Landscape in Clinton
 Sampson County
 TIP #: R-2303D(L)

Landscape Architect
Bob Kopetsky

SHEET DESCRIPTION:	PREL. DESIGN DATE:	7/21/21
	CHECKED BY & DATE:	K Cooper
	FINAL DESIGN DATE:	8/17/21

Planting Plan
 Landscape Plan Sheet

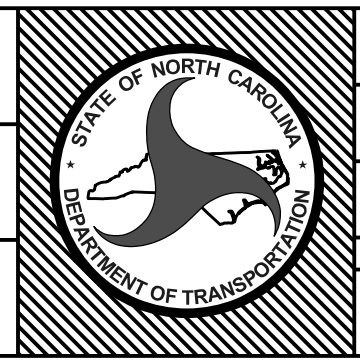

T.I.P. #	R-2303D(L)
WBS #	34416.3.15
FED I.D. #	-----
SHEET NO.:	L-3
TOTAL SHEET NO.:	L-19

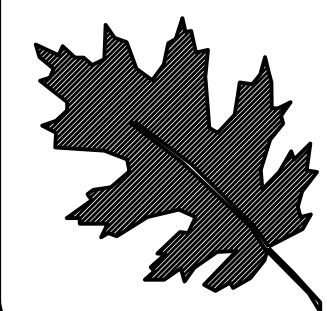
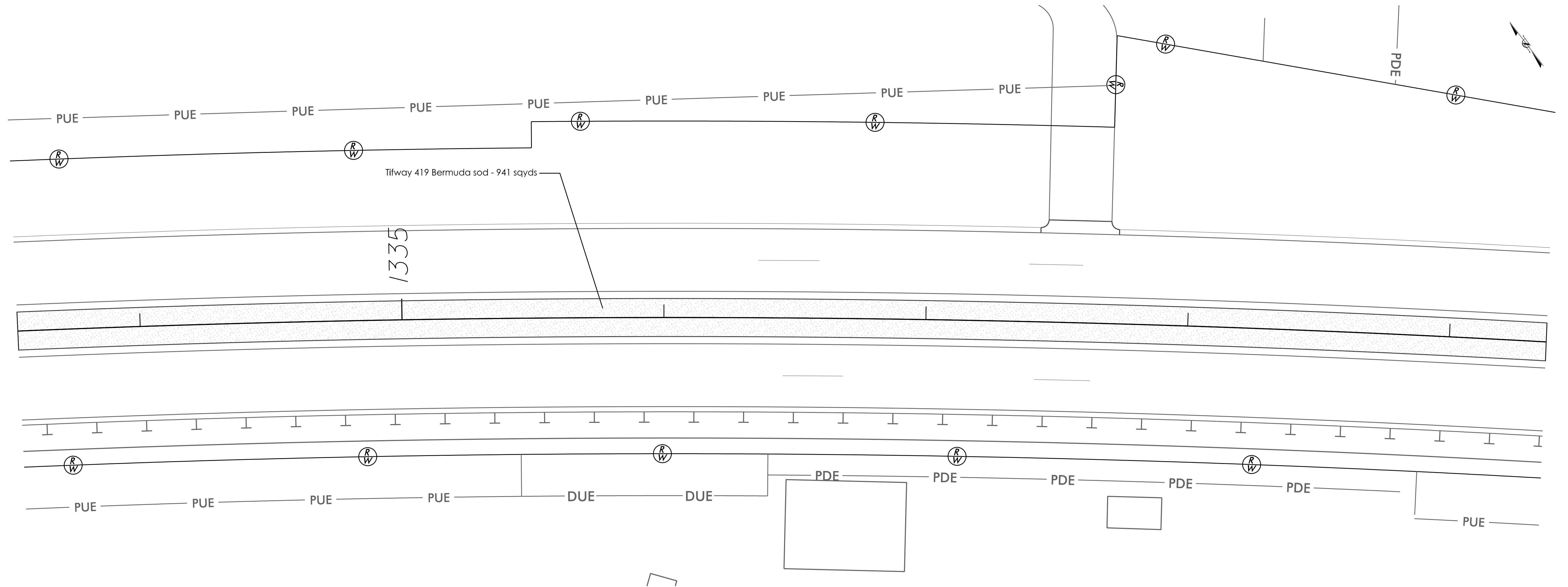

NCDOT - ROADSIDE ENVIRONMENTAL UNIT
 AESTHETIC ENGINEERING SECTION
 1557 MAIL SERVICE CENTER RALEIGH NC 27699-1557
 PH: 919-707-2935 FAX: 919-715-2554
http://www.ncdot.org/doh/operations/dp_chief_eng/roadside/

NC-24 Corridor Landscape in Clinton
 Sampson County
 TIP #: R-2303D(L)

Landscape Architect

Bob Kopetsky

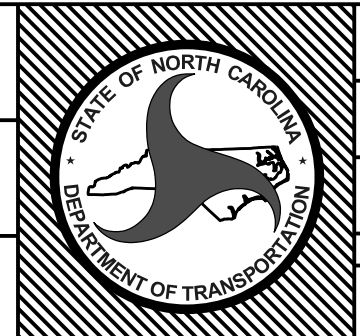
SHEET DESCRIPTION:	PREL. DESIGN DATE: 7/21/21	Planting Plan		T.I.P. # R-2303D(L)
	CHECKED BY & DATE: K Cooper	Landscape Plan Sheet		WBS # 34416.3.15
	FINAL DESIGN DATE: 8/17/21			FED I.D. # -----
			SHEET NO: L-4	TOTAL SHEET NO: L-19

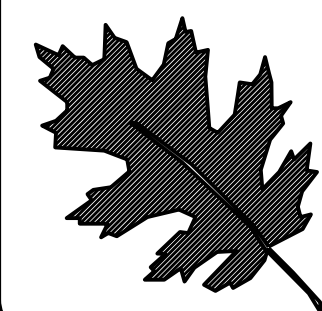
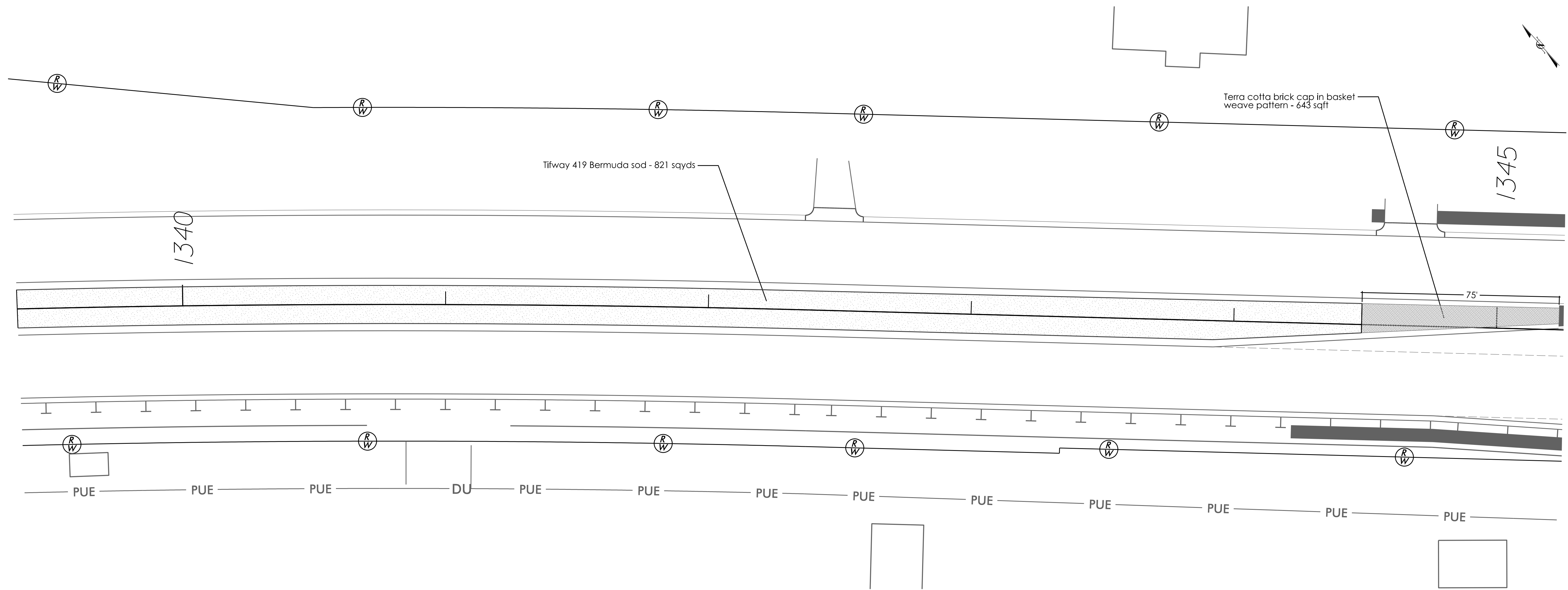

NCDOT - ROADSIDE ENVIRONMENTAL UNIT
 AESTHETIC ENGINEERING SECTION
 1557 MAIL SERVICE CENTER RALEIGH NC 27699-1557
 PH: 919-707-2935 FAX: 919-715-2554
http://www.ncdot.org/doh/operations/dp_chief_eng/roadside/

NC-24 Corridor Landscape in Clinton
 Sampson County
 TIP #: R-2303D(L)

Landscape Architect

Bob Kopetsky

SHEET DESCRIPTION:	PREL. DESIGN DATE:	7/21/21
	CHECKED BY & DATE:	K Cooper
	FINAL DESIGN DATE:	8/17/21

Planting Plan
Landscape Plan Sheet

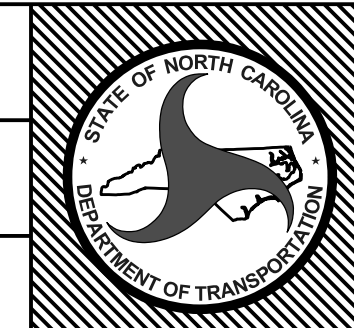

T.I.P. #	R-2303D(L)
WBS #	34416.3.15
FED I.D. #	-----
SHEET NO.:	TOTAL SHEET NO.:
L-5	L-19

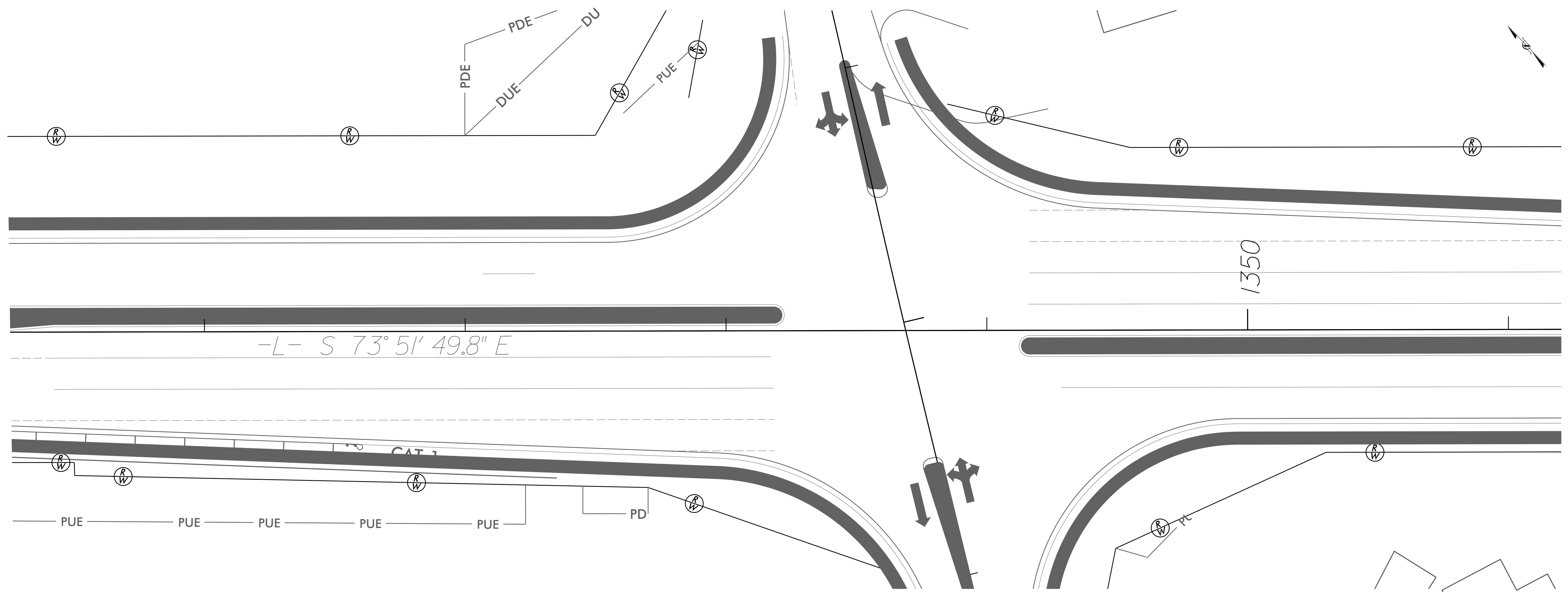

NO DESIGN ON THIS SHEET

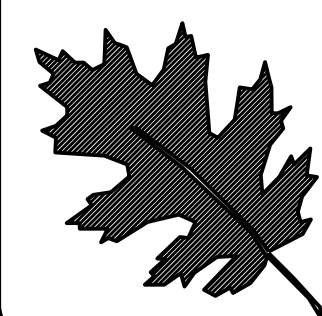

NCDOT - ROADSIDE ENVIRONMENTAL UNIT
 AESTHETIC ENGINEERING SECTION
 1557 MAIL SERVICE CENTER RALEIGH NC 27699-1557
 PH: 919-707-2935 FAX: 919-715-2554
http://www.ncdot.org/doh/operations/dp_chief_eng/roadside/

NC-24 Corridor Landscape in Clinton
 Sampson County
 TIP #: R-2303D(L)

Landscape Architect

Bob Kopetsky

SHEET DESCRIPTION:	PREL. DESIGN DATE:	7/21/21
	CHECKED BY & DATE:	K Cooper
	FINAL DESIGN DATE:	8/17/21

Planting Plan
Landscape Plan Sheet

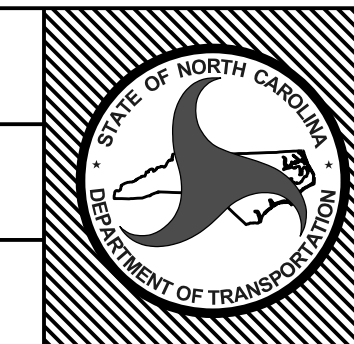

T.I.P. #	R-2303D(L)
WBS #	34416.3.15
FED I.D. #	-----
SHEET NO.:	L-6
TOTAL SHEET NO.:	L-19

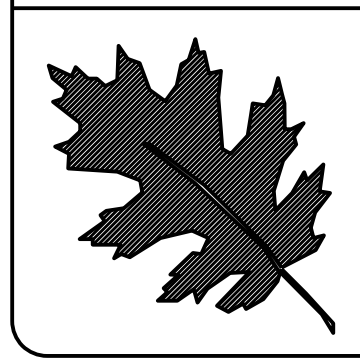
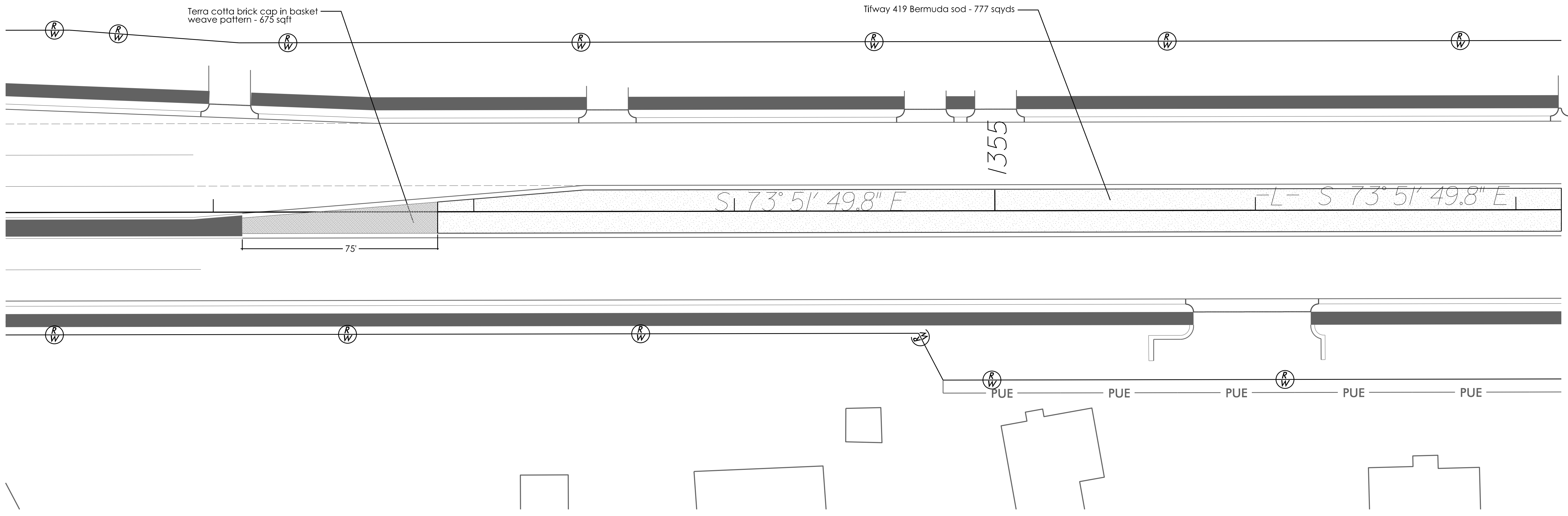

NCDOT - ROADSIDE ENVIRONMENTAL UNIT
 AESTHETIC ENGINEERING SECTION
 1557 MAIL SERVICE CENTER RALEIGH NC 27699-1557
 PH: 919-707-2935 FAX: 919-715-2554
http://www.ncdot.org/doh/operations/dp_chief_eng/roadside/

NC-24 Corridor Landscape in Clinton
 Sampson County
 TIP #: R-2303D(L)

Landscape Architect
Bob Kopetsky

SHEET DESCRIPTION:	PREL. DESIGN DATE:	7/21/21
	CHECKED BY & DATE:	K Cooper
	FINAL DESIGN DATE:	8/17/21

Planting Plan
 Landscape Plan Sheet

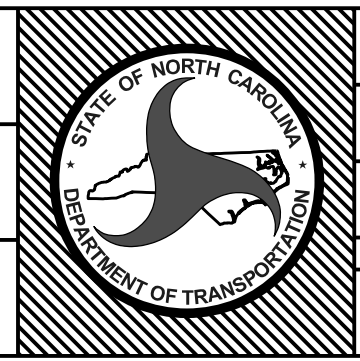

T.I.P. #	R-2303D(L)
WBS #	34416.3.15
FED I.D. #	-----
SHEET NO.:	L-7
TOTAL SHEET NO.:	L-19

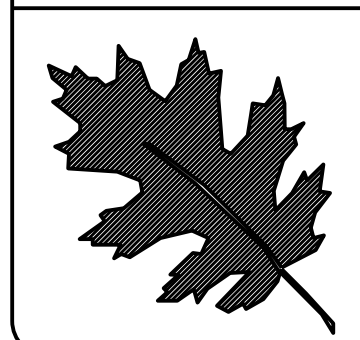
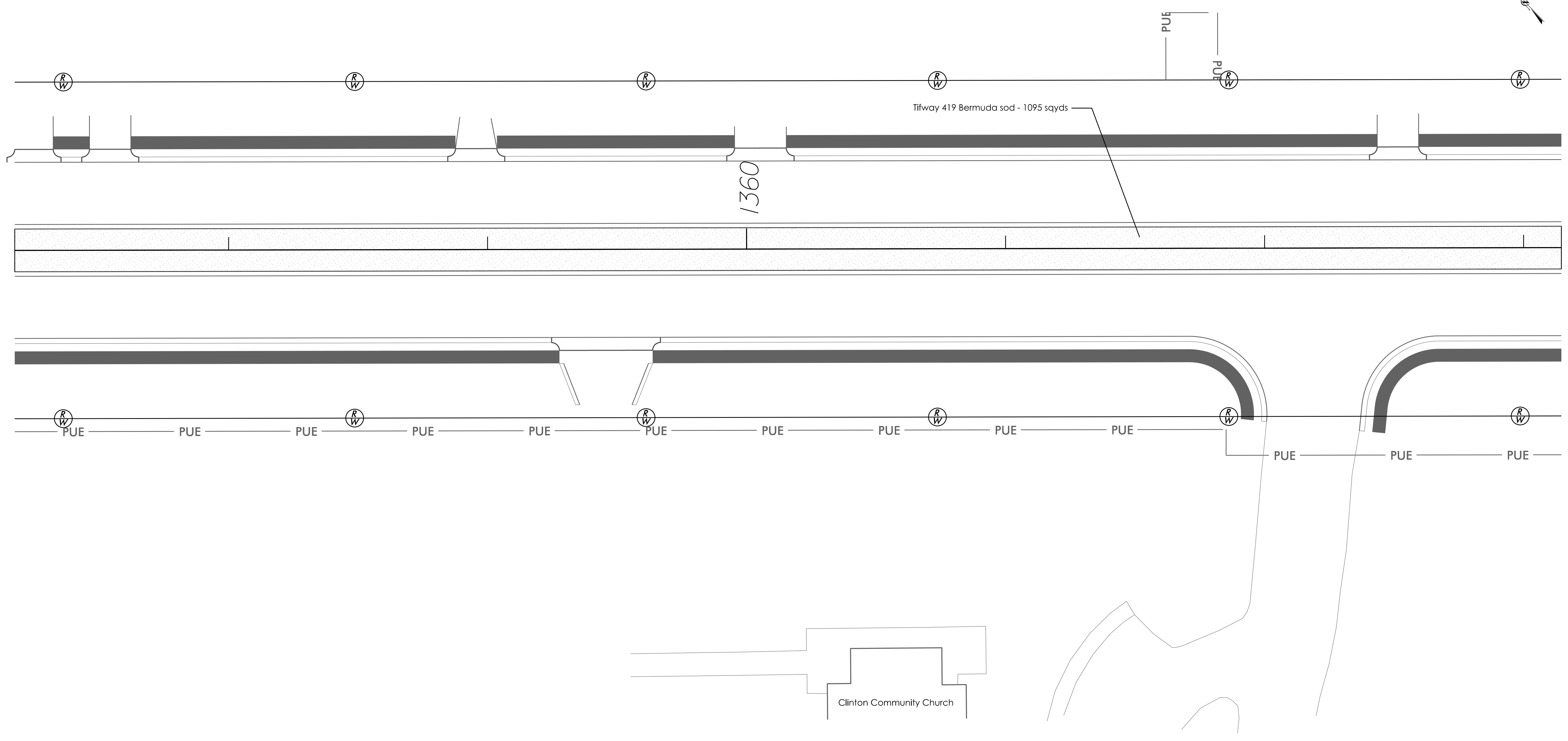

NCDOT - ROADSIDE ENVIRONMENTAL UNIT
 AESTHETIC ENGINEERING SECTION
 1557 MAIL SERVICE CENTER RALEIGH NC 27699-1557
 PH: 919-707-2935 FAX: 919-715-2554
http://www.ncdot.org/doh/operations/dp_chief_eng/roadside/

NC-24 Corridor Landscape in Clinton
 Sampson County
 TIP #: R-2303D(L)

Landscape Architect
Bob Kopetsky

SHEET DESCRIPTION:	PREL. DESIGN DATE:	7/21/21
	CHECKED BY & DATE:	K Cooper
	FINAL DESIGN DATE:	8/17/21

Planting Plan
Landscape Plan Sheet

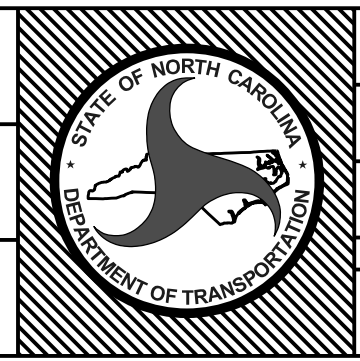

T.I.P. #	R-2303D(L)
WBS #	34416.3.15
FED I.D. #	-----
SHEET NO.:	L-8
TOTAL SHEET NO.:	L-19

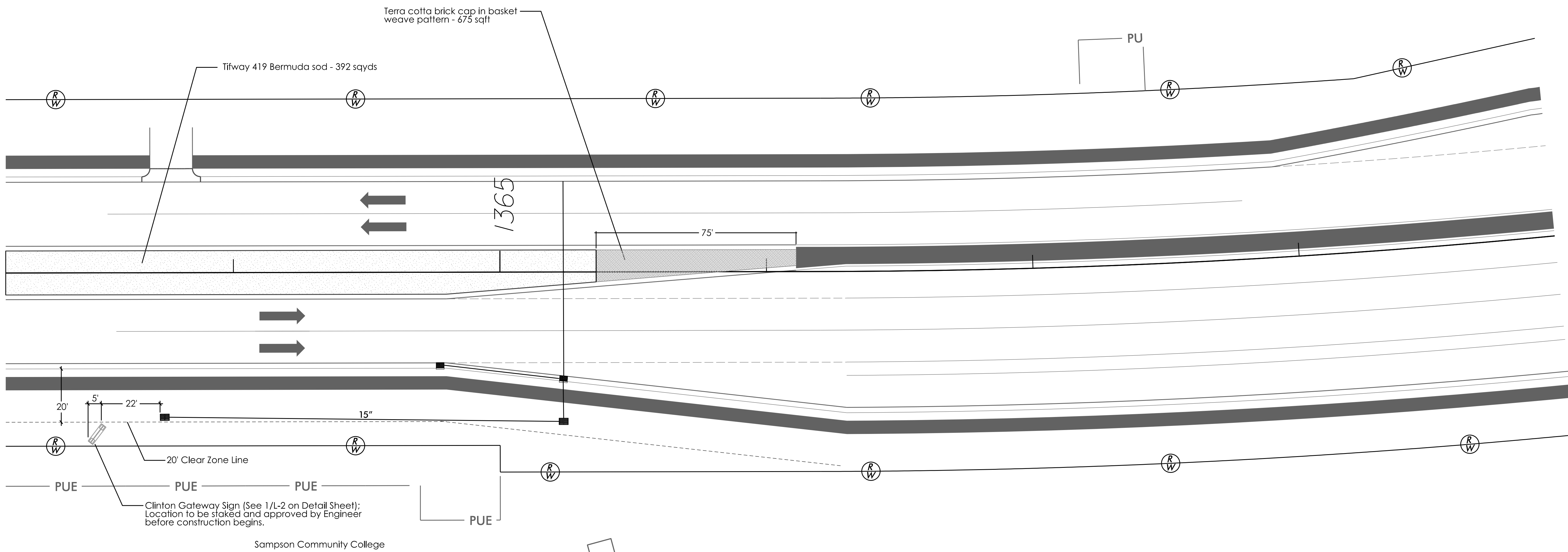



 NCDOT - ROADSIDE ENVIRONMENTAL UNIT
 AESTHETIC ENGINEERING SECTION
 1557 MAIL SERVICE CENTER RALEIGH NC 27699-1557
 PH: 919-707-2935 FAX: 919-715-2554
http://www.ncdot.org/doh/operations/dp_chief_eng/roadside/

NC-24 Corridor Landscape in Clinton
 Sampson County
 TIP #: R-2303D(L)

Landscape Architect

SHEET DESCRIPTION:	PREL. DESIGN DATE:	7/21/21
	CHECKED BY & DATE:	K Cooper
	FINAL DESIGN DATE:	8/17/21

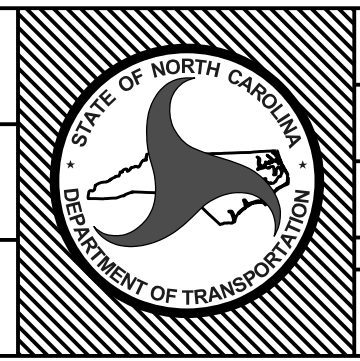
Planting Plan
 Landscape Plan Sheet



T.I.P. #	R-2303D(L)
WBS #	34416.3.15
FED I.D. #	-----
SHEET NO.:	L-9
TOTAL SHEET NO.:	L-19

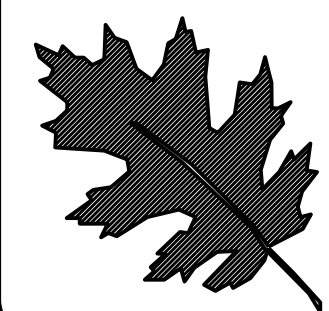
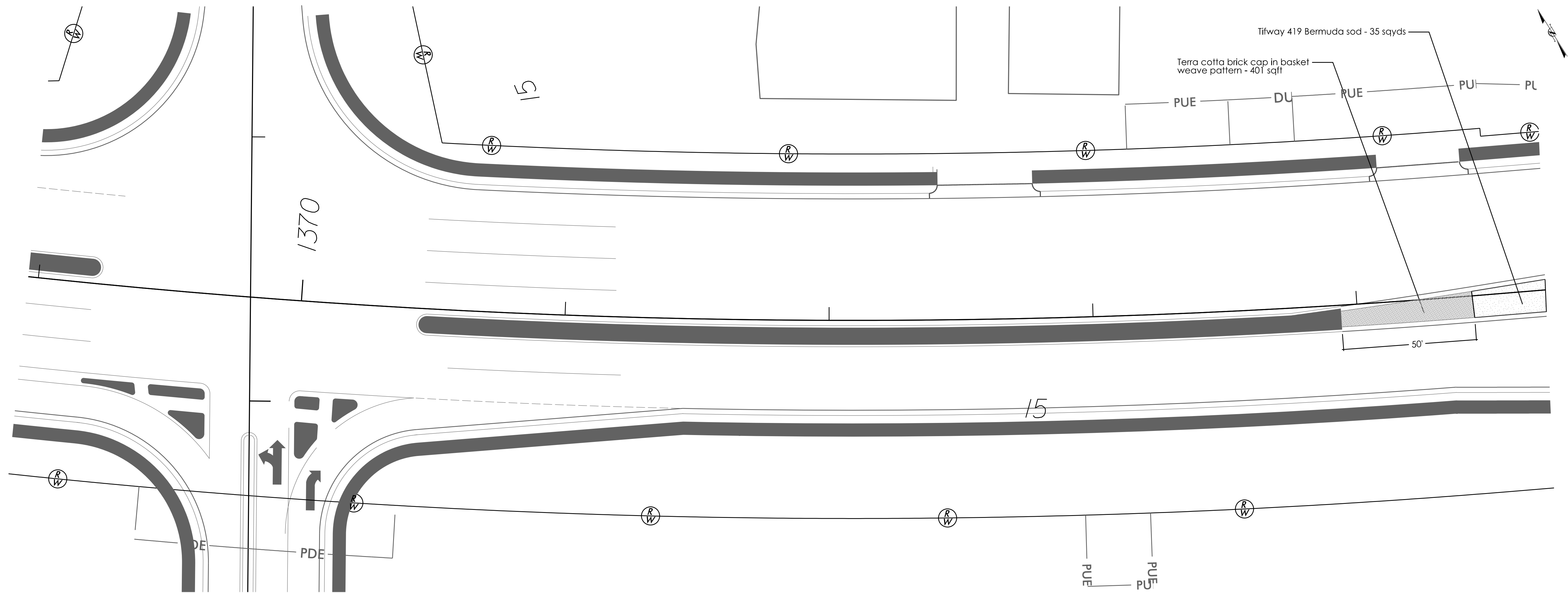

NCDOT - ROADSIDE ENVIRONMENTAL UNIT
 AESTHETIC ENGINEERING SECTION
 1557 MAIL SERVICE CENTER RALEIGH NC 27699-1557
 PH: 919-707-2935 FAX: 919-715-2554
http://www.ncdot.org/doh/operations/dp_chief_eng/roadside/

NC-24 Corridor Landscape in Clinton
 Sampson County
 TIP #: R-2303D(L)

Landscape Architect

Bob Kopetsky

SHEET DESCRIPTION:	PREL. DESIGN DATE:	7/21/21
	CHECKED BY & DATE:	K Cooper
	FINAL DESIGN DATE:	8/17/21

Planting Plan
Landscape Plan Sheet

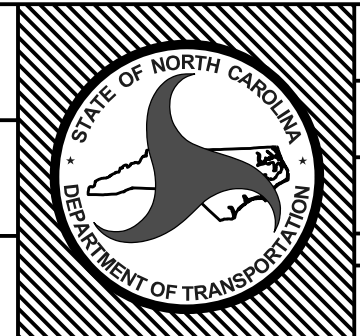

T.I.P. #	R-2303D(L)
WBS #	34416.3.15
FED I.D. #	-----
SHEET NO.:	L-10
TOTAL SHEET NO.:	L-19

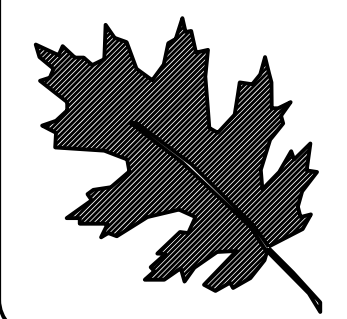
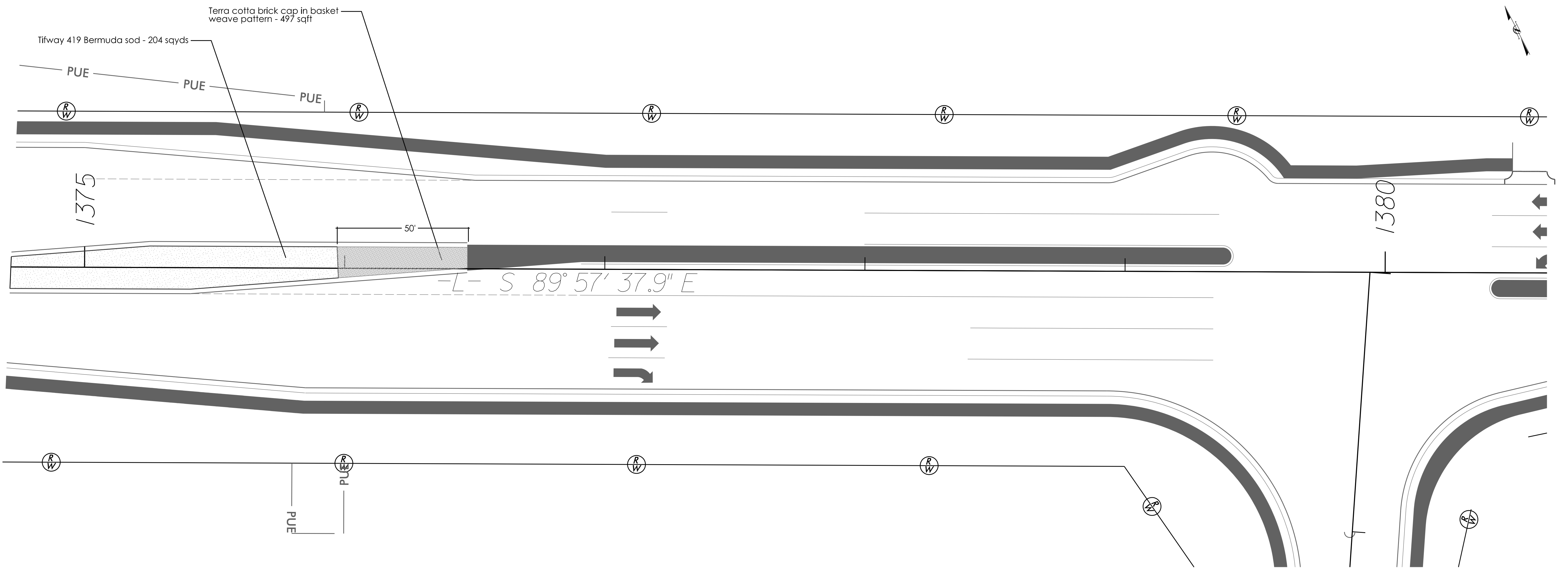

NCDOT - ROADSIDE ENVIRONMENTAL UNIT
 AESTHETIC ENGINEERING SECTION
 1557 MAIL SERVICE CENTER RALEIGH NC 27699-1557
 PH: 919-707-2935 FAX: 919-715-2554
http://www.ncdot.org/doh/operations/dp_chief_eng/roadside/

NC-24 Corridor Landscape in Clinton
 Sampson County
 TIP #: R-2303D(L)

Landscape Architect
Bob Kopetsky

SHEET DESCRIPTION:	PREL. DESIGN DATE:	7/21/21
	CHECKED BY & DATE:	K Cooper
	FINAL DESIGN DATE:	8/17/21

Planting Plan
 Landscape Plan Sheet

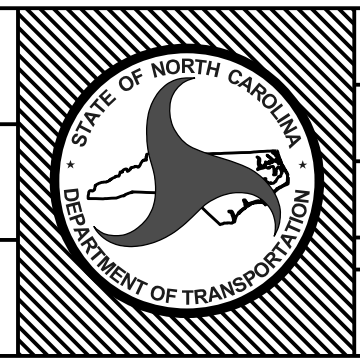

T.I.P. #	R-2303D(L)
WBS #	34416.3.15
FED I.D. #	-----
SHEET NO.:	L-11
TOTAL SHEET NO.:	L-19

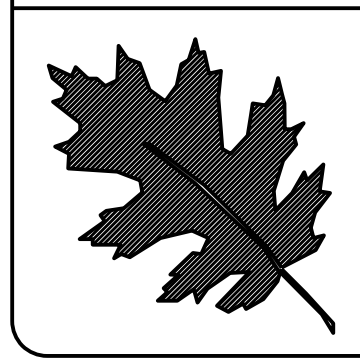
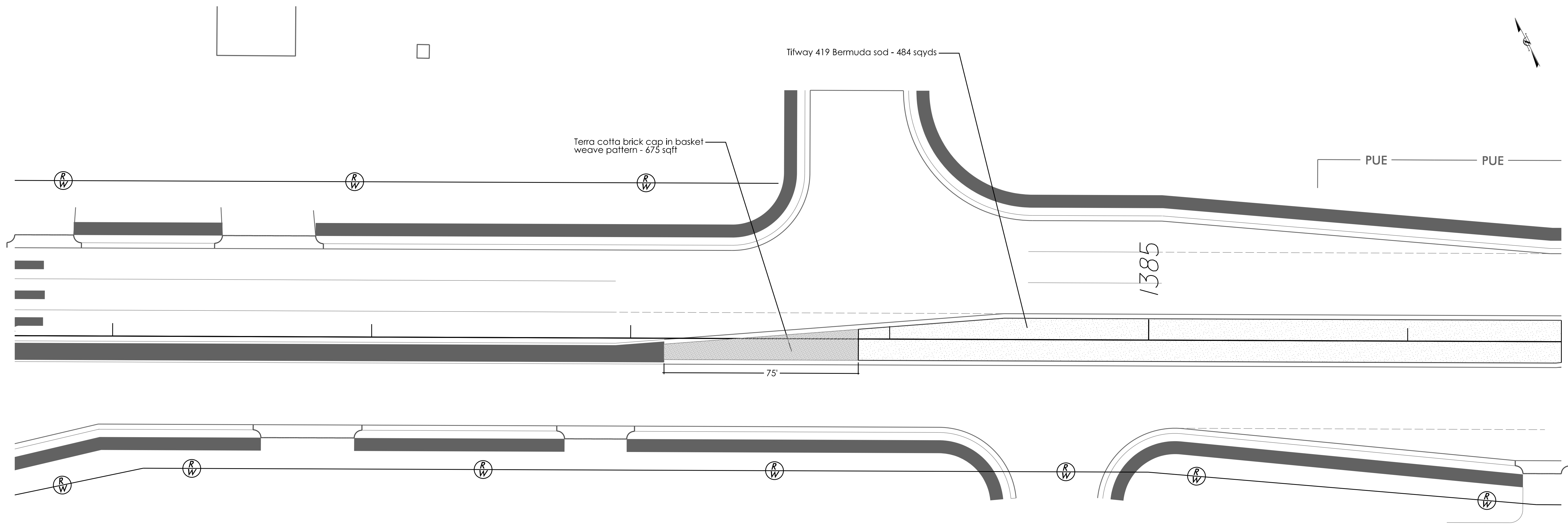

NCDOT - ROADSIDE ENVIRONMENTAL UNIT
 AESTHETIC ENGINEERING SECTION
 1557 MAIL SERVICE CENTER RALEIGH NC 27699-1557
 PH: 919-707-2935 FAX: 919-715-2554
http://www.ncdot.org/doh/operations/dp_chief_eng/roadside/

NC-24 Corridor Landscape in Clinton
 Sampson County
 TIP #: R-2303D(L)

Landscape Architect
Bob Kopetsky

SHEET DESCRIPTION:	PREL. DESIGN DATE:	7/21/21
	CHECKED BY & DATE:	K Cooper
	FINAL DESIGN DATE:	8/17/21

Planting Plan
 Landscape Plan Sheet

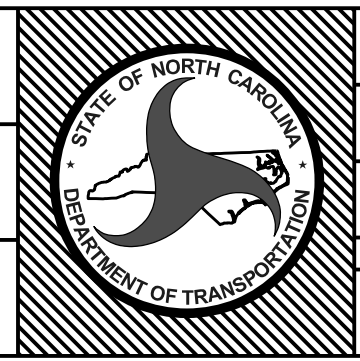

T.I.P. #	R-2303D(L)
WBS #	34416.3.15
FED I.D. #	-----
SHEET NO.:	L-12
TOTAL SHEET NO.:	L-19

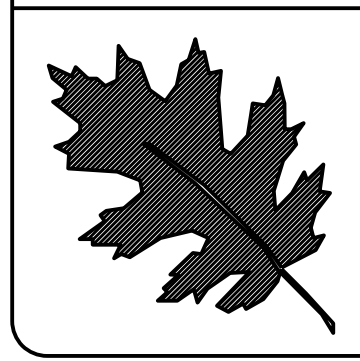
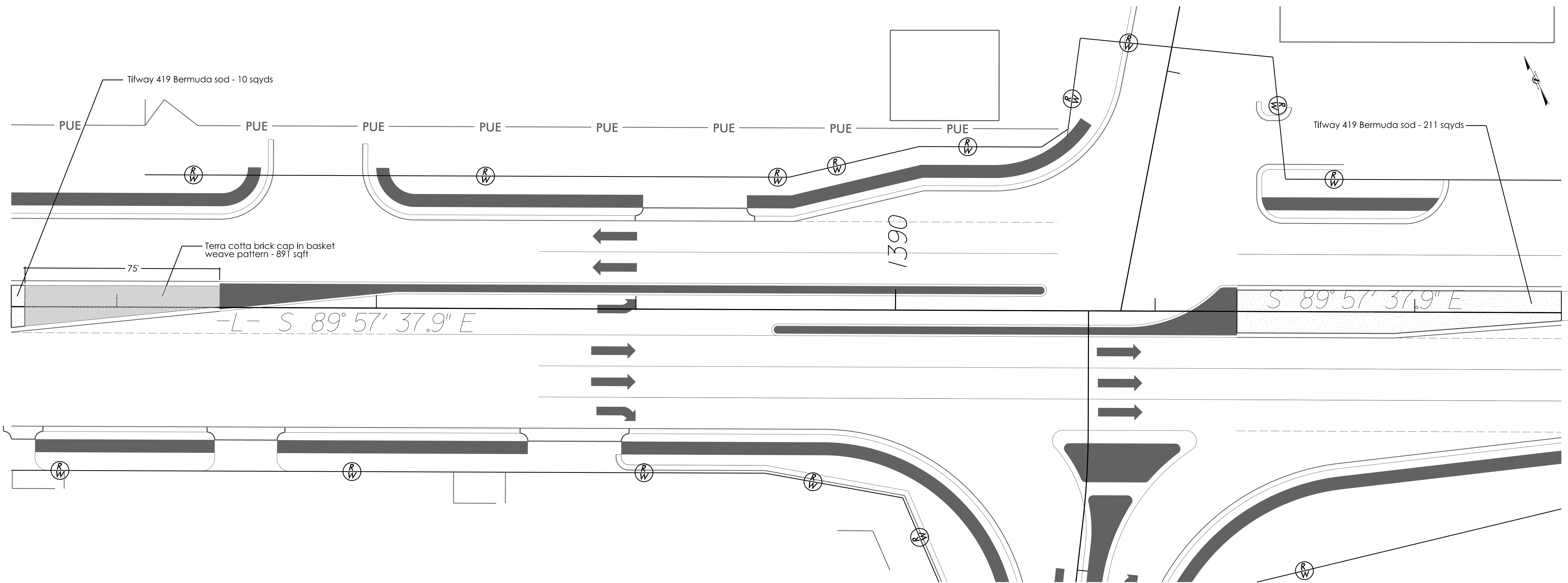

NCDOT - ROADSIDE ENVIRONMENTAL UNIT
 AESTHETIC ENGINEERING SECTION
 1557 MAIL SERVICE CENTER RALEIGH NC 27699-1557
 PH: 919-707-2935 FAX: 919-715-2554
http://www.ncdot.org/doh/operations/dp_chief_eng/roadside/

NC-24 Corridor Landscape in Clinton
 Sampson County
 TIP #: R-2303D(L)

Landscape Architect
Bob Kopetsky

SHEET DESCRIPTION:	PREL. DESIGN DATE:	7/21/21
	CHECKED BY & DATE:	K Cooper
	FINAL DESIGN DATE:	8/17/21

Planting Plan
Landscape Plan Sheet

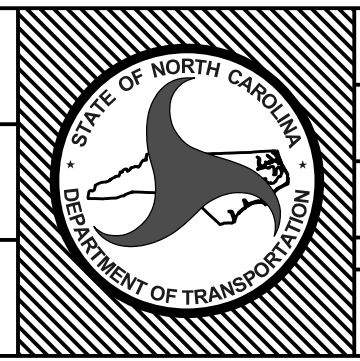

T.I.P. #	R-2303D(L)
WBS #	34416.3.15
FED I.D. #	-----
SHEET NO.:	L-13
TOTAL SHEET NO.:	L-19

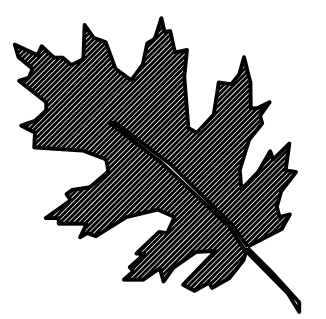
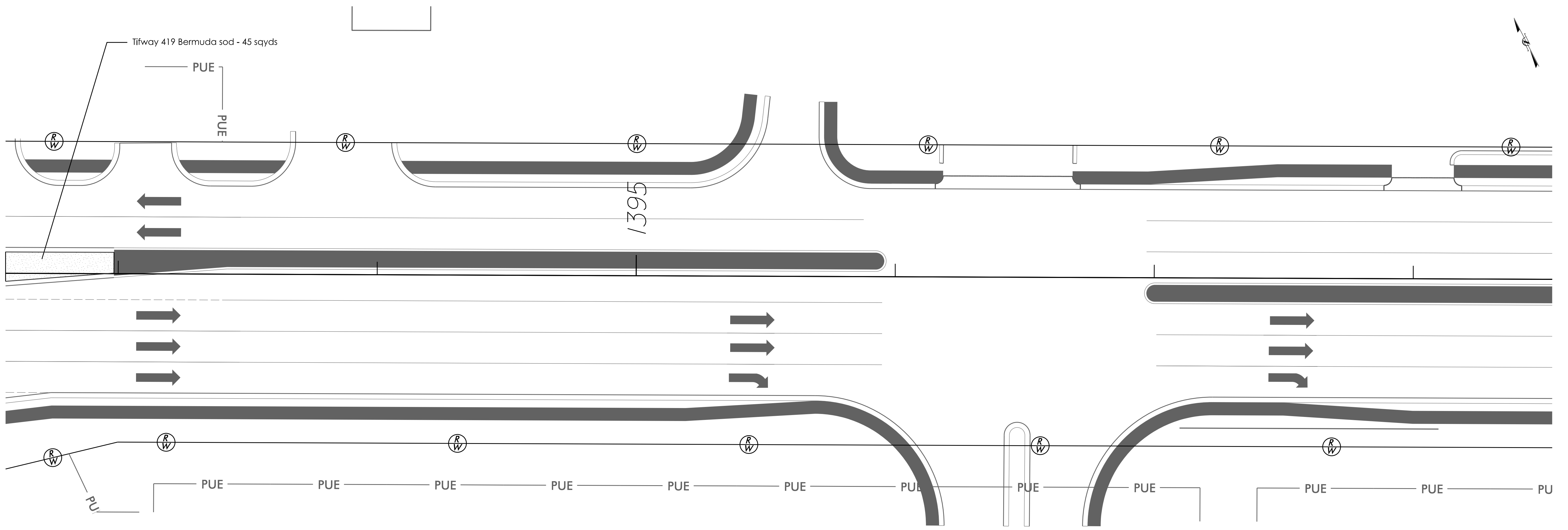

NCDOT - ROADSIDE ENVIRONMENTAL UNIT
 AESTHETIC ENGINEERING SECTION
 1557 MAIL SERVICE CENTER RALEIGH NC 27699-1557
 PH: 919-707-2935 FAX: 919-715-2554
http://www.ncdot.org/doh/operations/dp_chief_eng/roadside/

NC-24 Corridor Landscape in Clinton
 Sampson County
 TIP #: R-2303D(L)

Landscape Architect
Bob Kopetsky

SHEET DESCRIPTION:	PREL. DESIGN DATE:	7/21/21
	CHECKED BY & DATE:	K Cooper
	FINAL DESIGN DATE:	8/17/21

Planting Plan
Landscape Plan Sheet

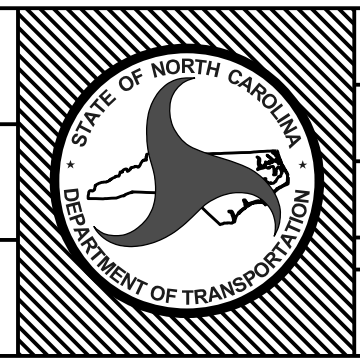

T.I.P. #	R-2303D(L)
WBS #	34416.3.15
FED I.D. #	-----
SHEET NO.:	L-14
TOTAL SHEET NO.:	L-19

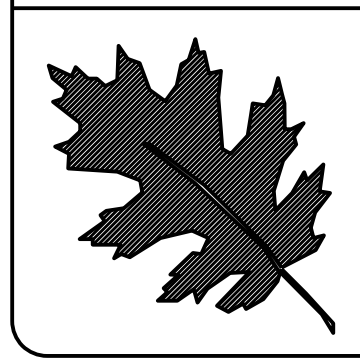
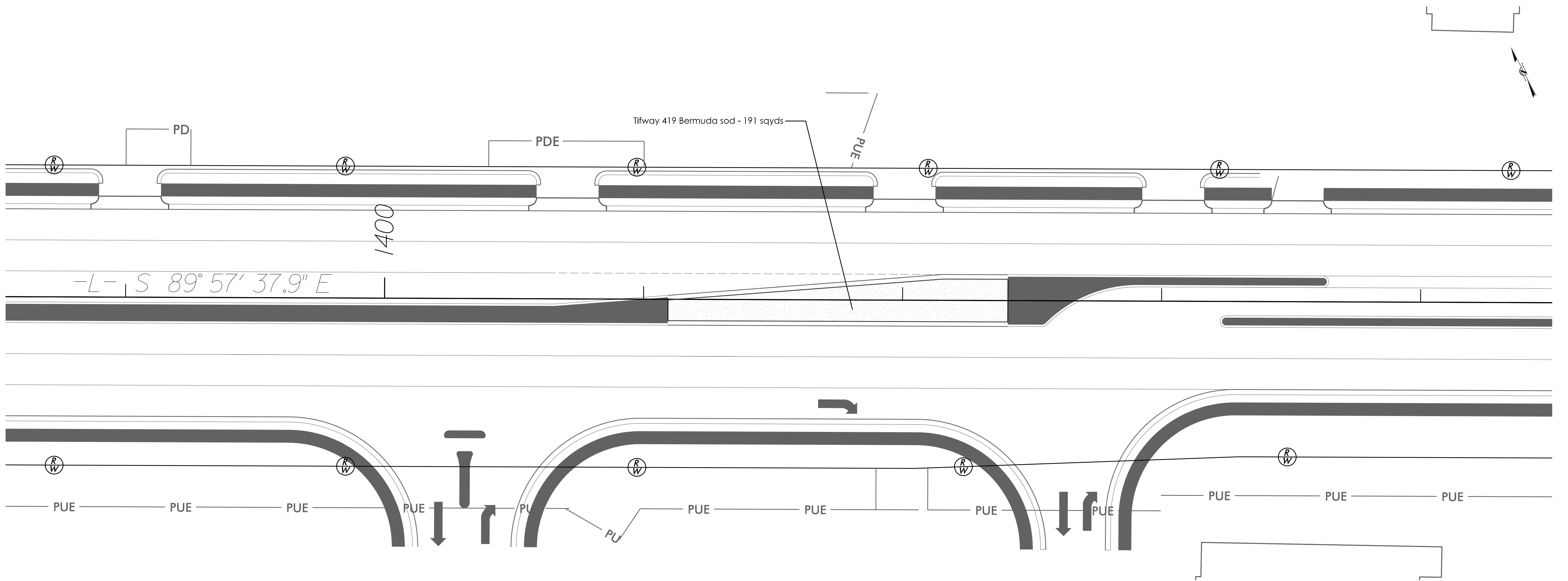

NCDOT - ROADSIDE ENVIRONMENTAL UNIT
 AESTHETIC ENGINEERING SECTION
 1557 MAIL SERVICE CENTER RALEIGH NC 27699-1557
 PH: 919-707-2935 FAX: 919-715-2554
http://www.ncdot.org/doh/operations/dp_chief_eng/roadside/

NC-24 Corridor Landscape in Clinton
 Sampson County
 TIP #: R-2303D(L)

Landscape Architect
Bob Kopetsky

SHEET DESCRIPTION:	PREL. DESIGN DATE:	7/21/21
	CHECKED BY & DATE:	K Cooper
	FINAL DESIGN DATE:	8/17/21

Planting Plan
Landscape Plan Sheet

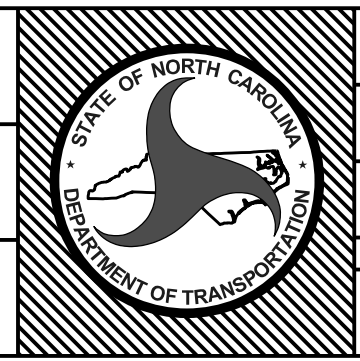

T.I.P. #	R-2303D(L)
WBS #	34416.3.15
FED I.D. #	-----
SHEET NO.:	L-15
TOTAL SHEET NO.:	L-19

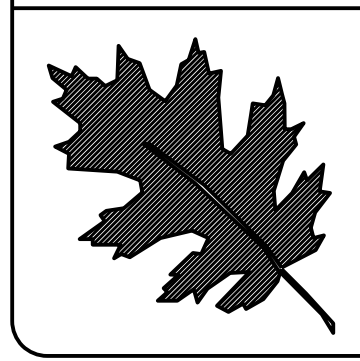
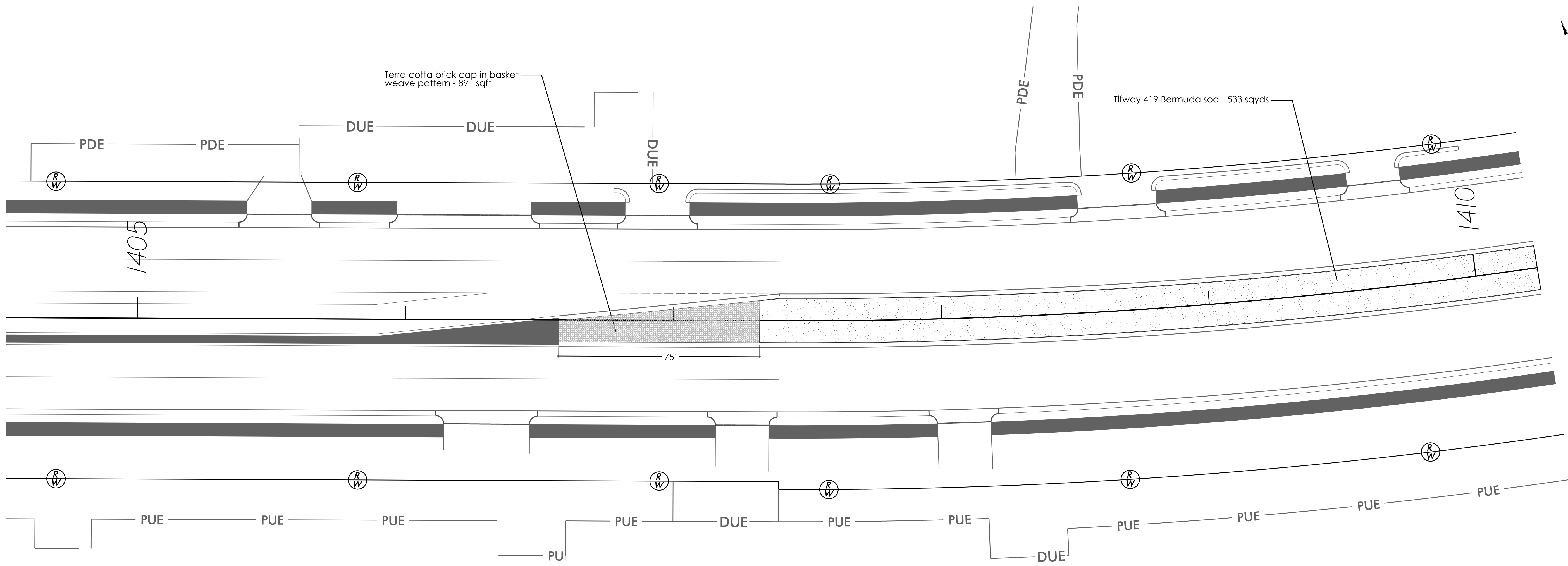

NCDOT - ROADSIDE ENVIRONMENTAL UNIT
 AESTHETIC ENGINEERING SECTION
 1557 MAIL SERVICE CENTER RALEIGH NC 27699-1557
 PH: 919-707-2935 FAX: 919-715-2554
http://www.ncdot.org/doh/operations/dp_chief_eng/roadside/

NC-24 Corridor Landscape in Clinton
 Sampson County
 TIP #: R-2303D(L)

Landscape Architect
 Bob Kopetsky

SHEET DESCRIPTION:	PREL. DESIGN DATE:	7/21/21
	CHECKED BY & DATE:	K Cooper
	FINAL DESIGN DATE:	8/17/21

Planting Plan
Landscape Plan Sheet

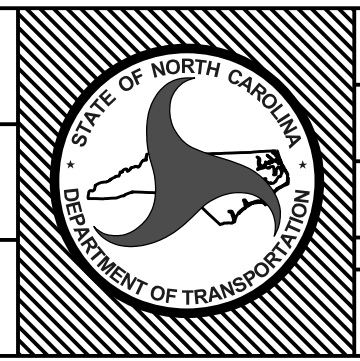

T.I.P. #	R-2303D(L)
WBS #	34416.3.15
FED I.D. #	-----
SHEET NO.:	L-16
TOTAL SHEET NO.:	L-19

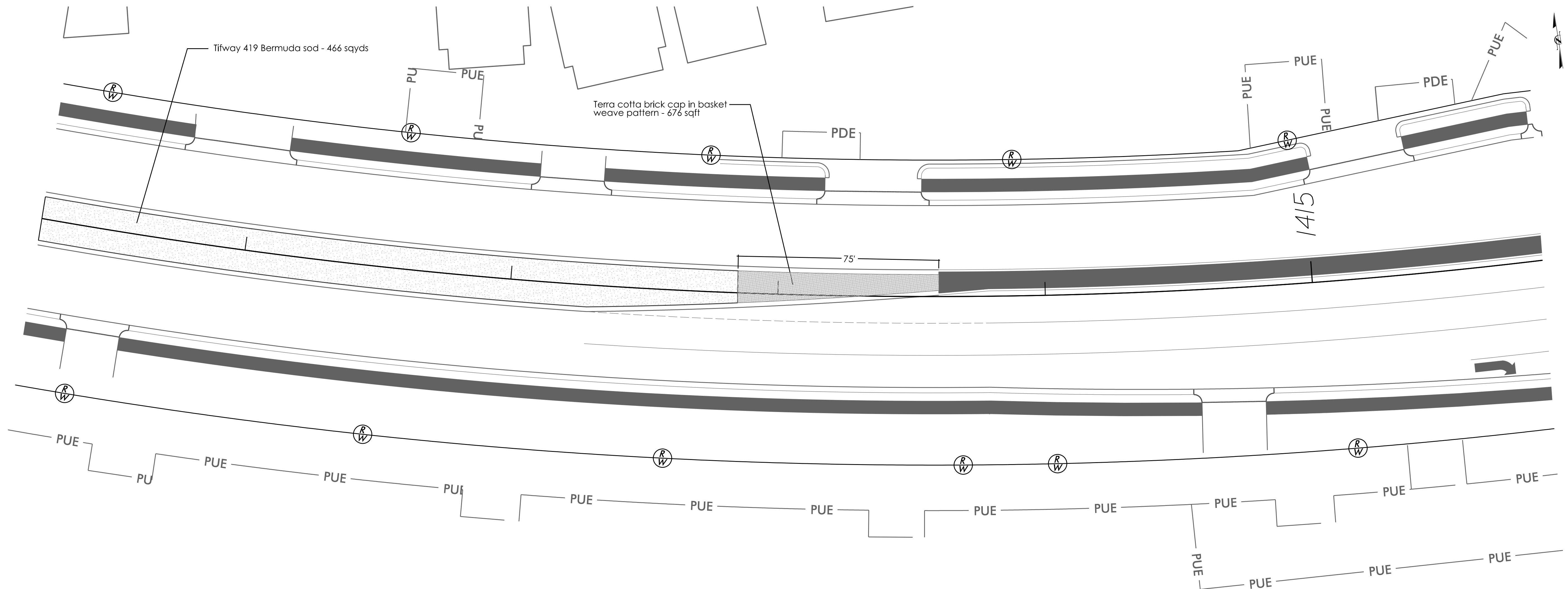



 NCDOT - ROADSIDE ENVIRONMENTAL UNIT
 AESTHETIC ENGINEERING SECTION
 1557 MAIL SERVICE CENTER RALEIGH NC 27699-1557
 PH: 919-707-2935 FAX: 919-715-2554
http://www.ncdot.org/doh/operations/dp_chief_eng/roadside/

NC-24 Corridor Landscape in Clinton
 Sampson County
 TIP #: R-2303D(L)

Landscape Architect

SHEET DESCRIPTION:	PREL. DESIGN DATE:	7/21/21
	CHECKED BY & DATE:	K Cooper
	FINAL DESIGN DATE:	8/17/21

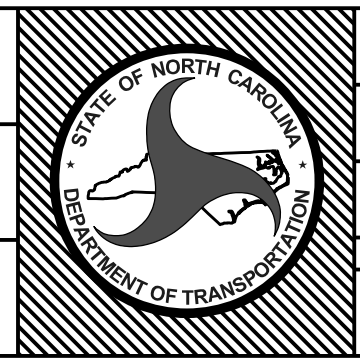
Planting Plan
Landscape Plan Sheet



T.I.P. #	R-2303D(L)
WBS #	34416.3.15
FED I.D. #	-----
SHEET NO.:	L-17
TOTAL SHEET NO.:	L-19

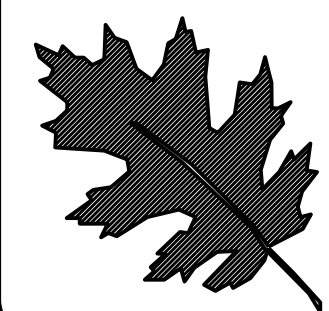
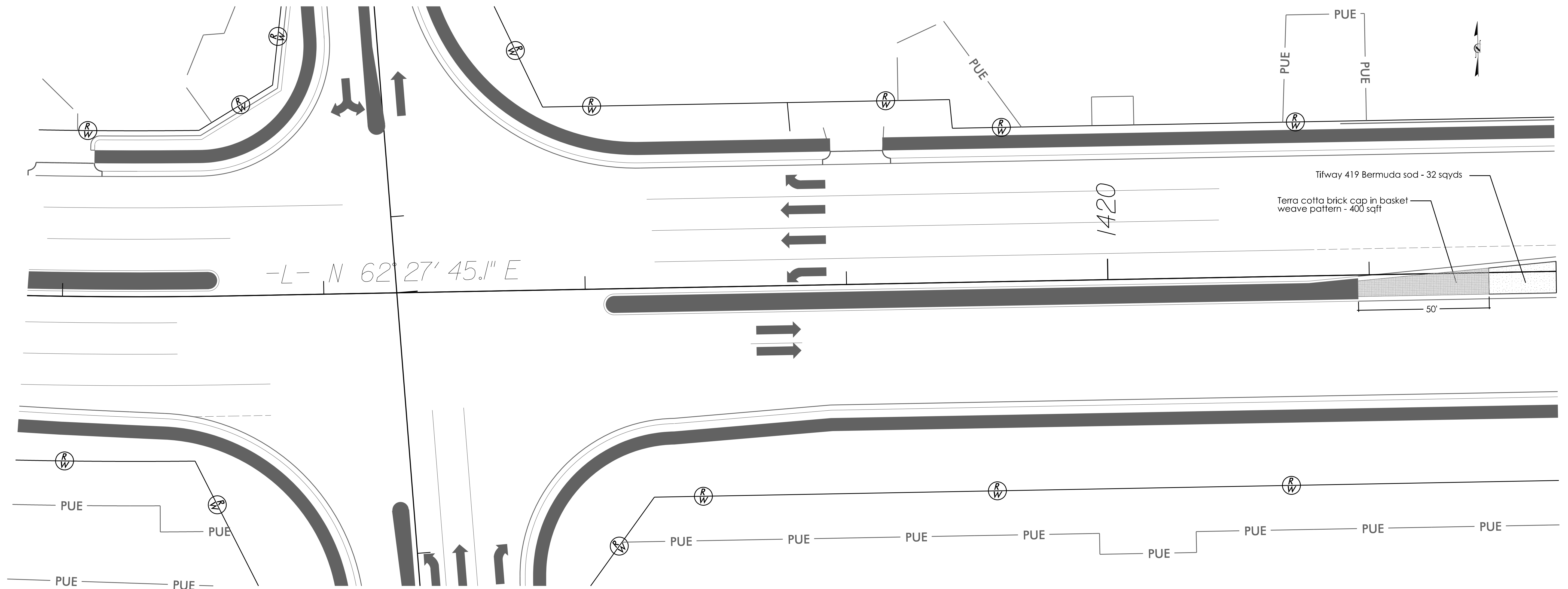

NCDOT - ROADSIDE ENVIRONMENTAL UNIT
 AESTHETIC ENGINEERING SECTION
 1557 MAIL SERVICE CENTER RALEIGH NC 27699-1557
 PH: 919-707-2935 FAX: 919-715-2554
http://www.ncdot.org/doh/operations/dp_chief_eng/roadside/

NC-24 Corridor Landscape in Clinton
 Sampson County
 TIP #: R-2303D(L)

Landscape Architect

Bob Kopetsky

SHEET DESCRIPTION:	PREL. DESIGN DATE:	7/21/21
	CHECKED BY & DATE:	K Cooper
	FINAL DESIGN DATE:	8/17/21

Planting Plan
Landscape Plan Sheet

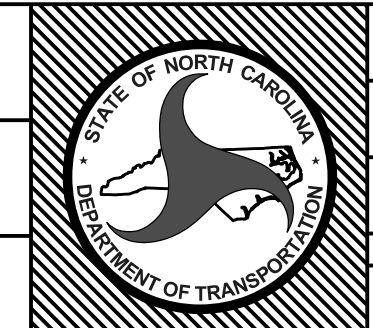

T.I.P. #	R-2303D(L)
WBS #	34416.3.15
FED I.D. #	-----
SHEET NO.:	L-18
TOTAL SHEET NO.:	L-19

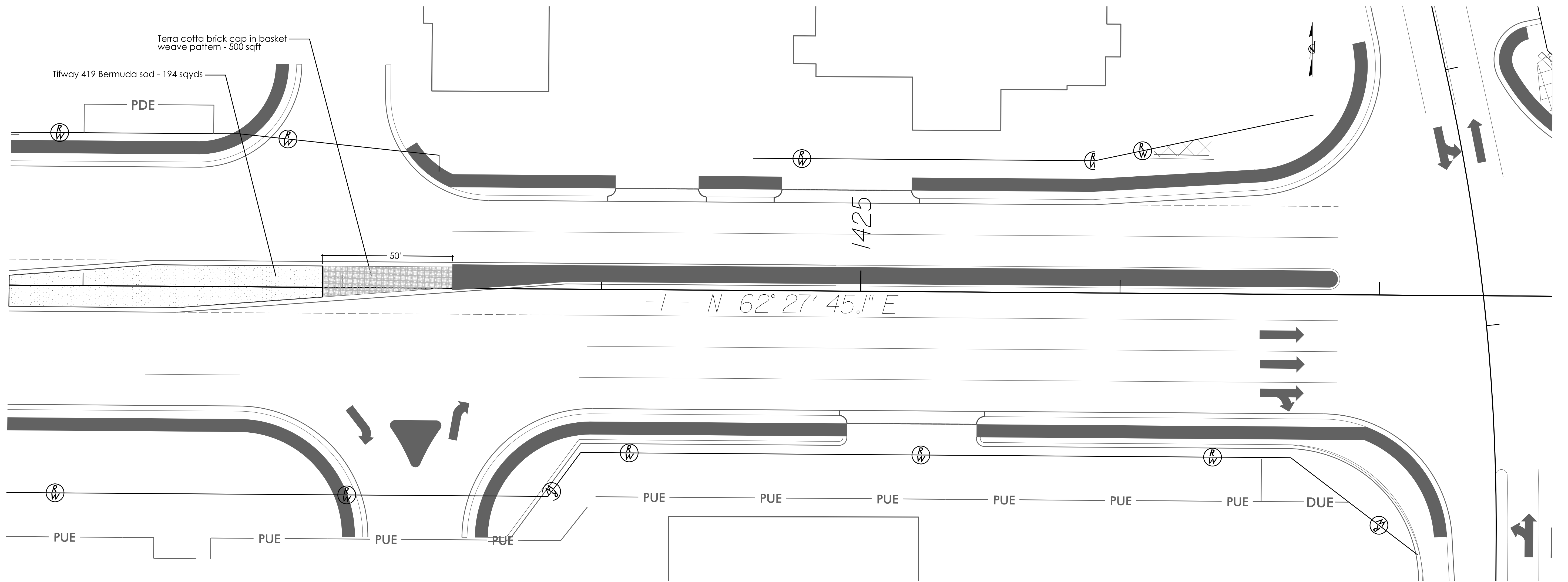



 NCDOT - ROADSIDE ENVIRONMENTAL UNIT
 AESTHETIC ENGINEERING SECTION
 1557 MAIL SERVICE CENTER RALEIGH NC 27699-1557
 PH: 919-707-2935 FAX: 919-715-2554
http://www.ncdot.org/doh/operations/dp_chief_eng/roadside/

NC-24 Corridor Landscape in Clinton
 Sampson County
 TIP #: R-2303D(L)

Landscape Architect

SHEET DESCRIPTION:	PREL. DESIGN DATE:	7/21/21
	CHECKED BY & DATE:	K Cooper
	FINAL DESIGN DATE:	8/17/21

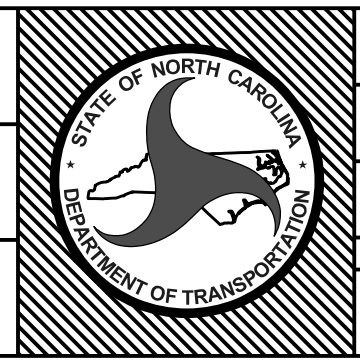
Planting Plan
 Landscape Plan Sheet



T.I.P. #	R-2303D(L)
WBS #	34416.3.15
FED I.D. #	-----
SHEET NO.:	L-19
TOTAL SHEET NO.:	L-19